

1 Gridscan 6000 Quick Start Guide

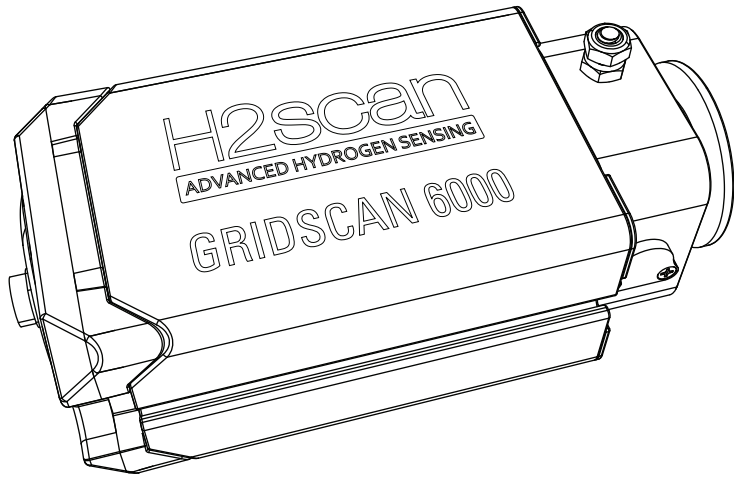

27215 TURNBERRY LANE
UNIT A, VALENCIA, CA
91355-1068

**READ MANUAL
BEFORE USE!**



P/N 90000218 R0

2

What's in the Box

- ▶ Gridscan 6000
- ▶ Power & Communication Cable - 5 Meter
- ▶ KF-40 Quick Clamp
- ▶ KF-40 Seal Ring
- ▶ Set Screw Lug
- ▶ Quick Start Guide

Tools Required

- ▶ Chemical-resistant O-Ring Seal Grease
- ▶ Channel Lock Plier
- ▶ Wire Stripper - For Preparing Wires for Connection
- ▶ Wire Cutters - For Cutting Wires to Length and Trimming Cable Ties
- ▶ Teflon Tape
- ▶ Flathead Screwdriver

3 Direct Mounting

1. Install KF-40 Adapter to transformer with teflon tape
2. Grease KF-40 Seal Ring (included)
3. Using Quick Flange Mount (included), install Gridscan 6000

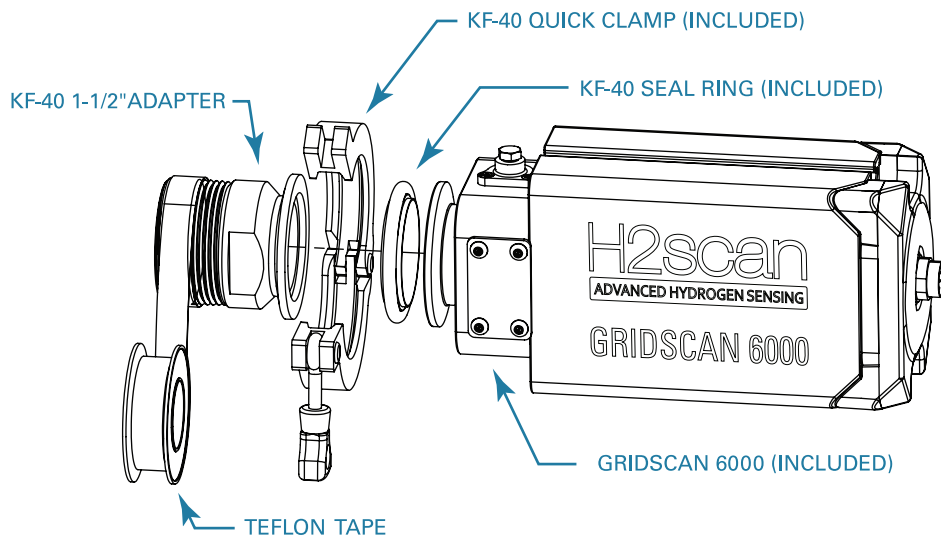

4

Air Bleed

1. Loosen the air bleed valve on the unit
2. Let the air sweep through until oil passes through the bleed valve
3. Tighten the air bleed valve to 31.2 in-lb

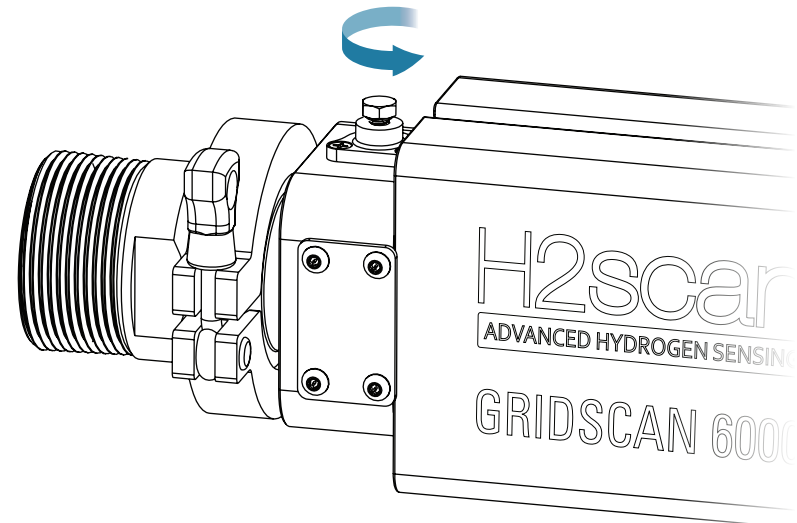

5 Connection **without** Conduit Adapter

Install Power & Communication Cable (included) to the rear end of the Gridscan 6000 and tighten to seal

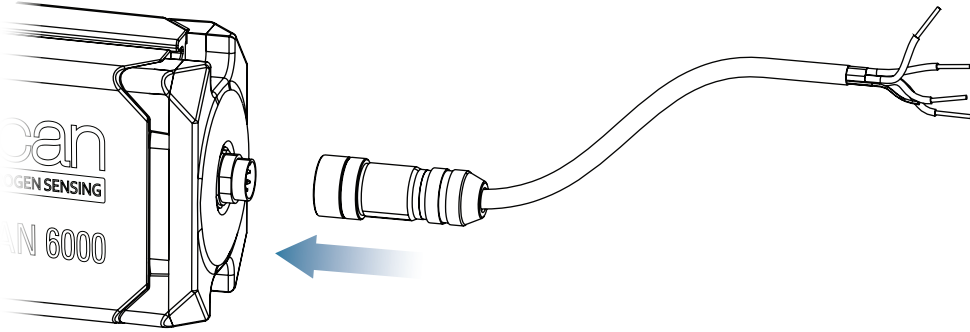

6 Connection **with** Conduit Adapter - Step 1

Using a flathead screwdriver, remove the clear endcap from the main unit

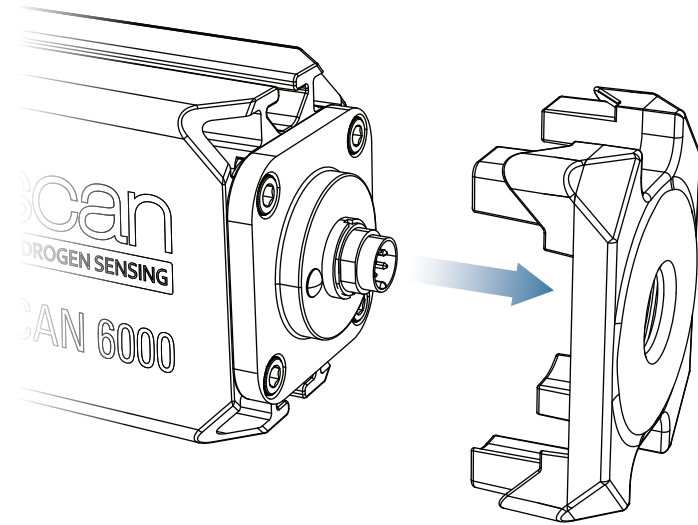

7 Connection **with** Conduit Adapter - Step 2

1. Pass the power cable through the Conduit Adapter Kit (Sold Separately)
2. Insert flex conduit into the conduit adapter and tighten the conduit nut
3. Install cable to the unit & use the channel lock to tighten
4. Slide the conduit adaptor kit to the unit slots

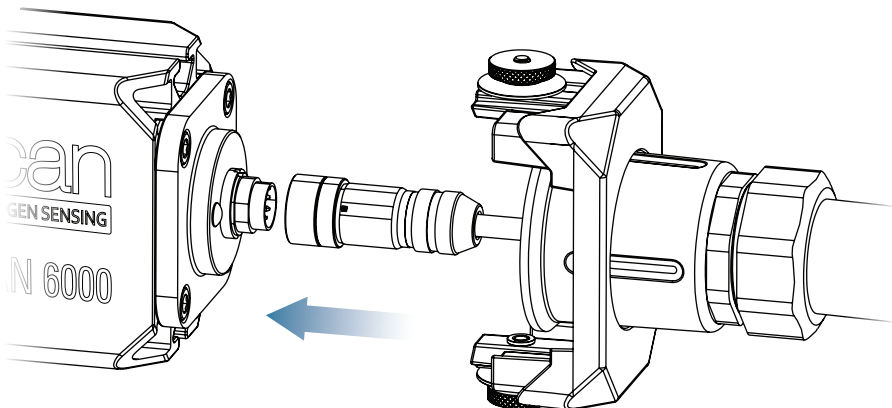

8 Connection **with** Conduit Adapter - Step 3

After inserting the conduit adapter guide into the unit slots, hand tighten the knurl nut on both ends

