

1 GSAO-2 Quick Start Guide

What's in the Box

- ▶ GSAO-2 Transformer Monitoring Controller
- ▶ 0.5" NPT Cable Glands
- ▶ 0.5" NPT Plugs
- ▶ 0.5" Lock Nuts & O-Rings
- ▶ 3 Meter Power Cord
- ▶ 1 Quick Start Guide
- ▶ 1 pk. Containing 4 ea #10 Stainless Steel Sheet Metal Screws & 6 ea Star Washers
- ▶ 2 Wiring Connectors that Mate to the PCBA
- ▶ 1 3mm Hex L-Key
- ▶ 7 Cable Ties

Tools Required

- ▶ Portable Drill - For Drilling Pilot Holes and Driving Mounting Screws
- ▶ 3mm (0.125") Drill Bit - For Drilling Pilot Holes into Metal
- ▶ Bit Extender - For Driving Mounting Screws
- ▶ #2 Phillips Drive Bit - For Driving Mounting Screws with Drill
- ▶ #2 Phillips Screw Driver - For Driving Screw for Cable Shield Ground
- ▶ Adjustable Wrench - For Tightening Gland Fittings
- ▶ Wire Stripper - For Preparing Wires for Connection
- ▶ Wire Cutters - For Cutting Wires to Length and Trimming Cable Ties
- ▶ Marker or Pencil - To Mark Hole Locations and Wire Cut Lengths



2 Mounting Options

A Direct Mount

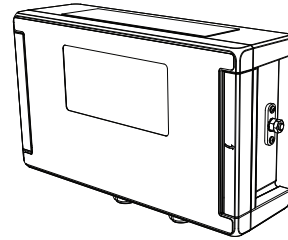

B Magnetic Plate (Sold separately)

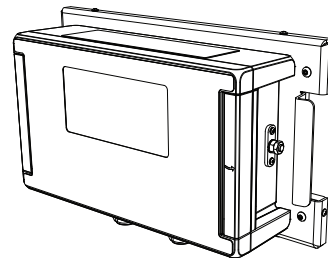

3 Mounting Option A

Step 1

Use the template on reverse side of Quick Start Guide to locate placement of pilot holes

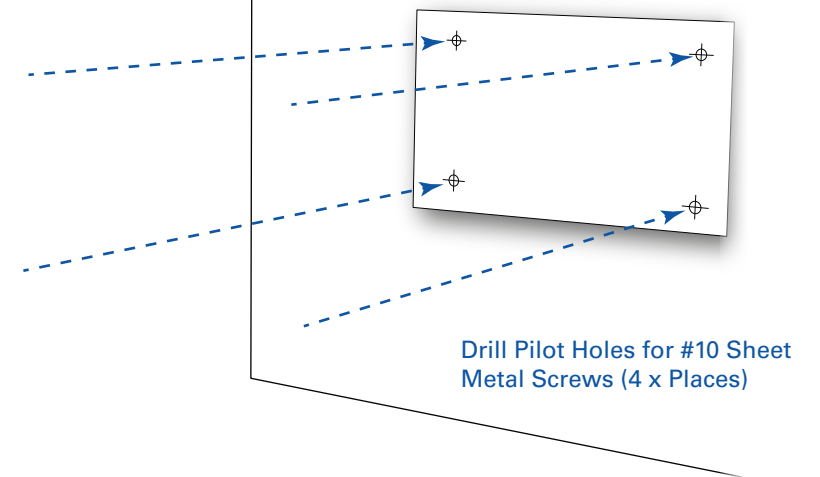

Drill Pilot Holes for #10 Sheet Metal Screws (4 x Places)

4 Mounting Option A

Step 2

Mount the GSAO-2 using 4 x #10 stainless steel screws and star washers (included). DO NOT OVERTIGHTEN



5 Mounting Option B

Step 1

Mount the GSAO-2 using 4 x #10 stainless steel screws and star washers (included) onto the magnetic plate DO NOT OVERTIGHTEN

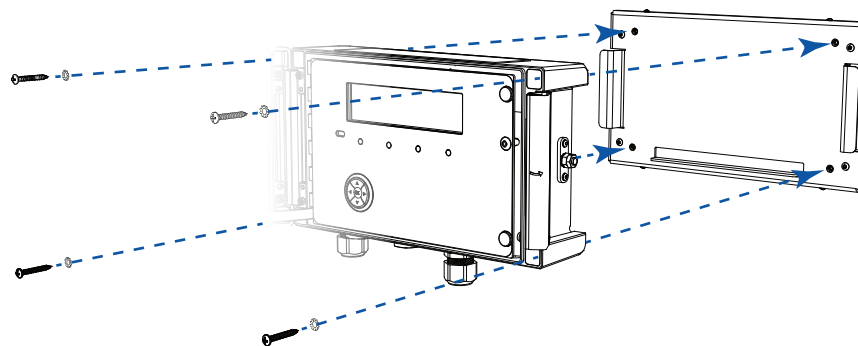

6 Mounting Option B

Step 2

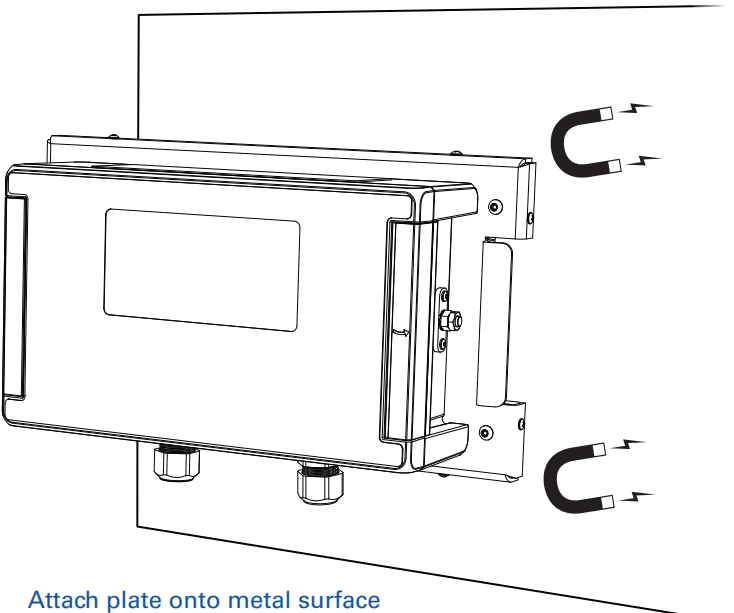

Attach plate onto metal surface

Drill Pilot Hole Template

11" (279mm)

6" (152mm)

P/N 9000223 R0

READ MANUAL
BEFORE USE



H2scan
ADVANCED HYDROGEN SENSING
27215 TURNBERRY LANE
UNIT A, VALENCIA, CA
91355-1068

