

GRIDSCAN™ 6000

MULTI-SENSE
MONITOR



Protect Transformers with All-In-One GRIDSCAN 6000: Hydrogen, Moisture, Temperature and Pressure Measurement

H2scan's GRIDSCAN 6000 breaks new ground in transformer monitoring, being the first in the market that combines four critical measurements; hydrogen, the first fault gas, moisture, pressure and temperature. The GRIDSCAN 6000 delivers continuous, real-time data, alerting asset managers to abnormal transformer conditions that may lead to catastrophic events. It delivers more capability than competitive monitors but at half the price.

The GRIDSCAN 6000's rich data set provides unprecedented visibility into the key parameters needed for real-time transformer health as well as fleetwide condition analytics.

Unlike competitive single-gas products, the GRIDSCAN 5000/6000 family incorporates H2scan's unique solid-state technology, eliminating the need for sensor maintenance, calibration and problematic consumables. The patented H2scan sensor is recognized in the industry as the "gold standard" and carries an exclusive 10-year warranty. It provides true set-and-forget monitoring (no more monitoring the monitor), allowing maintenance teams to focus on distressed assets identified by the GRIDSCAN sensors. reducing OPEX while extending the life of critical transformer assets.

- The only transformer monitor that combines hydrogen, moisture, pressure and temperature measurement
- Market-leading range of environmental operating conditions supported (hot/cold/salt water/submersible)
- Ideal for a fleetwide IoT deployment strategy, but also supports conventional SCADA connectivity
- Detects pressure drops associated with ballistic damage

Transform Your Transformer Monitoring Program

Short Time to Value:

Hours, not weeks or months

Longest Life Hydrogen Sensor:

10-year warranty on the hydrogen sensing element

First and Only Multi-Parameter Visibility: Hydrogen, moisture, pressure and temperature

Rugged & Reliable: Rated for harsh environmental conditions

Broad Connectivity: IoT/SCADA/ADMS ready with Modbus or DNP3

Flexible Integration: Wired or optional wireless communication capabilities

Standard 3-year warranty on the product



Imagine knowing the condition of all your transformers. Not just the select few. Imagine knowing, based on real data, where to focus your Capital and O&M spend? And imagine getting that without increasing your maintenance budget? The GRIDSCAN 6000 from H2scan makes that a reality by combining hydrogen, moisture, pressure and temperature measurements in one reliable, long-lasting and maintenance-free monitoring package.

Certifications: The GRIDSCAN 6000 meets all relevant global monitoring standards for transformer installations.

Operating Conditions

Insulating Liquid Temperature	
Operating	-40 to 105° C
Survival	-40 to 135° C
Insulating Liquid Supported	Mineral oil, silicone, natural ester, synthetic ester
Environmental	
Operating Temperature	-40° C to 70° C
Storage Temperature	-40° C to 85° C
Ambient Humidity	0 to 100% RH, condensing
Oil Humidity	0 to 95% RH, non-condensing
Ingress Protection	IP68; 25 feet water for 14 days (IEC 60529)
Marine Rating	Salt water condensing (IEC60068-2-11)
Operating Altitude	Up to 3000 m above sea level
Operating Pressure at Sensor	0.1 to 2 bar absolute (1.45 to 30 psia)
Mechanical	
Dimensions H x W x D	19.4 x 8.8 x 6.7 mm (7.63 x 3.47 x 2.65 in)
Weight	1.82 kg (4.01 lb)
Electrical	
Voltage Input	12 - 30 VDC
Max Power Consumption	12W
Communication	
Output Signal	3 wire RS-485, Modbus RTU, 5 pin M16 connector for power and communication
Data Log Storage	Dynamic
Other	
Designed Life Expectancy	10+ years
Standard Warranty	3 years
Calibration Interval	No periodic calibration required
Certifications	IEC 60068-2, IEC 60068-2-30, IEC 60529, EN55011, EN 61000-4, EN 61326-1, FCC Part 15, IEC 61010, refer to manual for specific closes

Sensors Performance Parameters

Hydrogen	
Measurement Range	25 to 5000 ppm
Accuracy	±20% of reading or ±25 ppm, whichever is greater
Repeatability	±10% of reading or ±25 ppm, whichever is greater
Response Time	<60 minutes once H2 reaches the sensor
Cross sensitivity	Less than 2% cross-sensitivity to other gases (CO, CO2, Hydrocarbons)
Moisture	
Measurement Range (Water Activity)	0 to 95% RS
Accuracy (a _w)	± 2% RS at <20% range ± 8% RS at 20-50% range
Repeatability	±2% RS
Pressure	
Measurement Range	0 to 205 kPa (0 to 30 psia) Absolute
Accuracy	± 2% FS
Repeatability	± 0.6 kPa (± 1 PSI)
Temperature	
Measurement Range	-40 to 125° C
Accuracy	± 0.1° C
Repeatability	<2° C

GRIDSCAN 6000 Dimensions

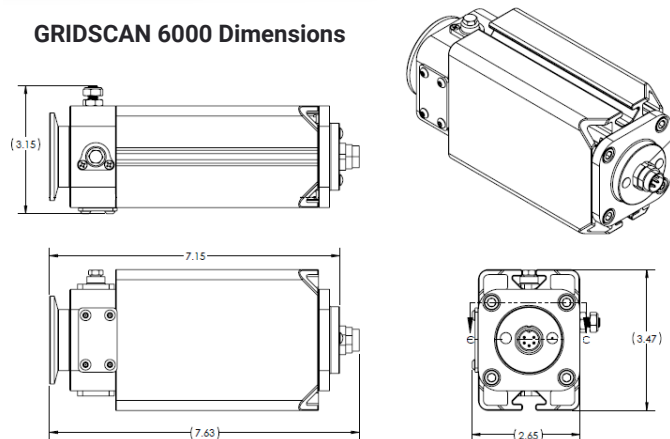

Specifications subject to change without notice
Printed Documents are uncontrolled.
© 2024 H2scan