

**H2scan**<sup>®</sup>  
Advanced Hydrogen Sensing



OPERATING MANUAL

# GRIDSCAN AO-1

## Analog Output Module

27215 Turnberry Lane, Unit A  
Valencia, CA 91355, USA  
Tel: (661) 775-9575  
E-mail: [hello@h2scan.com](mailto:hello@h2scan.com)  
Website: [www.h2scan.com](http://www.h2scan.com)

## IMPORTANT NOTICES



Read and understand this operating manual before installing or using the unit. If this equipment is used in a manner not specified by H2scan, the protection provided by this equipment may be impaired.

**LIMITATION OF LIABILITY** - seller shall under no circumstances be liable for any incidental, consequential, special, punitive, or other damages, including, but not limited to, loss of business or profit, promotional or manufacturing expenses, injury to reputation, or loss of customer, based on any alleged negligence, breach of warranty, strict liability, breach of contract, or any other legal theory arising out of the use, misuse, purchase, sale or possession of its goods or its performance of this contract to the extent that such liability extends seller's obligations beyond the price paid by buyer to seller for the item on which such claim is based. Seller advises buyer to perform acceptable tests on all hardware prior to deployment and to perform maintenance as described in the seller's instruction guide. Under no circumstances shall the equipment provided hereunder be used in a manner where it is the sole protective system for facilities, equipment, and personnel safety; the equipment is intended for use in conjunction with other appropriate protective systems.

## LIMITED WARRANTY

**H2scan Limited Warranty:** Each GSAO-1 analog output module ("Product") will conform, as to all substantial operational features, to the Product specifications set forth in this Manual and will be free of defects which substantially affect such Product's performance for thirty-six (36) months from the ship date for such Product.

**Must Provide Notice of Defect:** If you have a Product that you believe is defective, you must notify H2scan in writing, within the warranty period of your claim regarding any such defect.

**Return Product to H2scan for Repair, Replacement or Credit:** The customer is responsible for shipping and handling costs. If the Product is found defective by H2scan, H2scan's sole obligation under this warranty is to either (i) repair the Product, (ii) replace the Product, or (iii) issue a credit for the purchase price for such Product, the remedy to be determined by H2scan on a case-by-case basis. A valid RMA number must be assigned by H2scan and clearly marked on the package when the unit is returned.

**Voided Warranty:** H2scan's 3-year Limited Warranty is void for any of the following:

- Unauthorized repair work performed at the customer's location or conducted by anyone other than H2scan's factory trained technicians.
- Equipment or parts that have been tampered with, misused, neglected, mishandled, improperly adjusted, or modified in any way without the written consent of H2scan.
- Equipment or parts that have been damaged due to shipping, misuse, accidents, mishandling, neglect, or problems with electrical power sources.
- Repair work performed during the warranty period does not prolong the warranty period past the original period.
- System operation in incorrect or inappropriate environments.
- Usage that is not in accordance with system guidelines or an operator's failure to follow manual instructions.

**LIMITATION OF WARRANTY:** THE ABOVE IS A LIMITED WARRANTY AS IT IS THE ONLY WARRANTY MADE BY H2SCAN. H2SCAN MAKES NO OTHER WARRANTY EXPRESS OR IMPLIED AND EXPRESSLY EXCLUDES ALL WARRANTIES OF MERCHANTABILITY AND FITNESS FOR A PARTICULAR PURPOSE. YOUR SOLE REMEDY HEREUNDER IS REPAIR OR REPLACEMENT OF THE PRODUCT OR A CREDIT FOR THE PURCHASE PRICE FOR SUCH PRODUCT, THE PARTICULAR REMEDY TO BE DETERMINED BY H2SCAN ON A CASE-BY-CASE BASIS. H2SCAN SHALL HAVE NO LIABILITY WITH RESPECT TO ITS OBLIGATIONS UNDER THIS AGREEMENT FOR CONSEQUENTIAL, EXEMPLARY, OR INCIDENTAL DAMAGES EVEN IF IT HAS BEEN ADVISED OF THE POSSIBILITY OF SUCH DAMAGES. THE STATED EXPRESS WARRANTY IS IN LIEU OF ALL LIABILITIES OR OBLIGATIONS OF H2SCAN FOR DAMAGES ARISING OUT OF OR IN CONNECTION WITH THE DELIVERY, USE OR PERFORMANCE OF THE PRODUCTS.

**CONTENTS**

**1 INTRODUCTION ..... 4**

**2 FEATURES ..... 4**

2.1 OUT OF THE BOX ..... 4

2.2 TOOLS FOR MOUNTING AND COMMISSIONING ..... 5

2.3 MECHANICAL ..... 5

2.4 ENCLOSURE SEALING ..... 5

2.5 ELECTRICAL FEATURES ..... 6

**3 SPECIFICATIONS ..... 6**

3.1 CERTIFICATIONS ..... 7

**4 PRODUCT OVERVIEW ..... 8**

4.1 FRONT VIEW FEATURES: ..... 8

4.2 OPEN VIEW FEATURES: ..... 8

**5 LABELING ..... 9**

**6 ENCLOSURE ACCESS ..... 9**

**7 MOUNTING ..... 10**

**8 ELECTRICAL INTERFACE ..... 12**

8.1 GLAND FITTINGS ..... 12

8.2 CABLES ..... 13

8.3 WIRING CONNECTIONS ..... 13

8.3.1 Earth Grounding the GSAO-1 Module ..... 14

8.3.2 GRIDSCAN 5000 Hydrogen Sensor Wiring Connections ..... 14

8.3.3 Customer Wiring Connections ..... 15

8.3.4 Customer Wiring Terminations (Not at GSAO-1) ..... 17

8.3.5 Wire Dressing ..... 17

8.4 POWER SUPPLY ..... 18

**9 OPERATION ..... 18**

9.1 STARTUP ..... 18

9.2 FRONT PANEL LEDs ..... 19

9.3 ANALOG OUTPUT ..... 19

9.4 SERVICE CONDITIONS ..... 19

**10 CONFIGURATION MODE ..... 20**

10.1 GAS PHASE OR OIL PHASE ..... 21

10.2 CHANGING THE SENSOR SYSTEM ..... 21

10.3 CONFIGURATION MODE ..... 22

10.3.1 Entering Configuration Mode ..... 22

10.3.2 Test Mode ..... 22

10.3.3 Oil Type Selection ..... 23

10.3.4 Analog Output Scaling ..... 24

10.3.5 Exiting Configuration Mode ..... 25

**11 RE-SEALING THE GSAO-1 ..... 26**

**12 TROUBLESHOOTING ..... 27**

**13 UNIQUE LED PATTERNS ..... 28**

**14 ANALOG OUTPUT RANGE INFORMATION ..... 28**

## 1 Introduction

The GSAO-1 Analog Output Module is designed to provide an accurate, reliable, and robust 4-20mA analog output for the GRIDSCAN 5000 Hydrogen Sensor system. The robust electronics and physical designs are appropriate for use in electrical substation and varied transformer locations, and over a wide range of environmental conditions.

The GSAO-1 is powered with nominal 9 to 48 VDC, which is passed through to the GRIDSCAN 5000 Hydrogen Sensor System. Only two cables are required: one to connect the GSAO-1 Module to the GRIDSCAN 5000 Hydrogen Sensor with power and communications, and one from the customer supplying DC power and taking the analog signal out to the customer's data system.

The GSAO-1 automatically detects whether the GRIDSCAN 5000 sensor is configured and calibrated for use in gas phase or in oil. It is designed to allow the user to configure and scale the analog output based on specific Hydrogen concentrations during installation and can also be used to select and change the oil type during installation. LEDs give visual confirmation of settings.

The GSAO-1 has easily visible LEDs to indicate that the unit is powered and to indicate any service conditions.

The small and compact size allows for easy installation almost anywhere, and the enclosure allows for use of the supplied cable gland fittings or conduit fittings for a secure and rugged installation.

This document has been updated for use with GSAO-1 firmware revision **ao1r004**.

## 2 Features

### 2.1 Out of the Box

Every GSAO-1 Analog Output Module is shipped with the following:

- One GSAO-1 Analog Output Module
- One package containing 4 each #10 stainless steel sheet metal screws and 6 each star washers
- One External Grounding Kit
- Two Wiring Connectors that mate to the printed circuit board assembly
- One Package containing 1 screw and star washer for internal cable shield grounding
- One Flat Blade Screwdriver for making electrical wiring connections
- One Desiccant Package for moisture removal inside of the GSAO-1 Module
- One 3mm Hex L-Key for opening and securing the enclosure cover
- One Wooden Golf Tee for changing DIP switch settings
- Seven Cable Ties for dressing wires
- One Quick-Start Guide Including:
  - ✓ Package Content List
  - ✓ Tools Required for installation
  - ✓ 1:1 Template for easily identifying mounting hole locations
  - ✓ Mounting and Grounding Instructions
  - ✓ Wire Stripping Length Guide and Ruler
  - ✓ Wiring Instructions
  - ✓ Configuration Instructions
  - ✓ Help and Contact Information

## 2.2 Tools for Mounting and Commissioning

For mounting the GSAO-1 to panels, the following tools are required:

- Electrical Drill with Bit Extender – to drill pilot holes and hold the driver bit
- 3 mm (1/8”) Hardened Drill Bit – for making pilot holes
- #2 Phillips Head Drive Bit – to drive the mounting screws with drill
- #2 Phillips Head Screwdriver – to secure cable shield grounding
- Adjustable Wrench – to tighten the cable gland fittings
- Wire Cutters – to trim wires to length and trim cable ties
- Wire Strippers – to properly strip wires without damage to the conductors
- Marker or Pencil – to mark holes to drill and wiring stripping

## 2.3 Mechanical

The GSAO-1 Analog Output Module has a rugged waterproof and dustproof mechanical assembly design for various transformer applications. The enclosure is easily mounted using the four mounting holes and the included #10 18-8 stainless steel screws. The GSAO-1 is rated IP68 and can be used in most environments.

Overall dimensions are shown below.

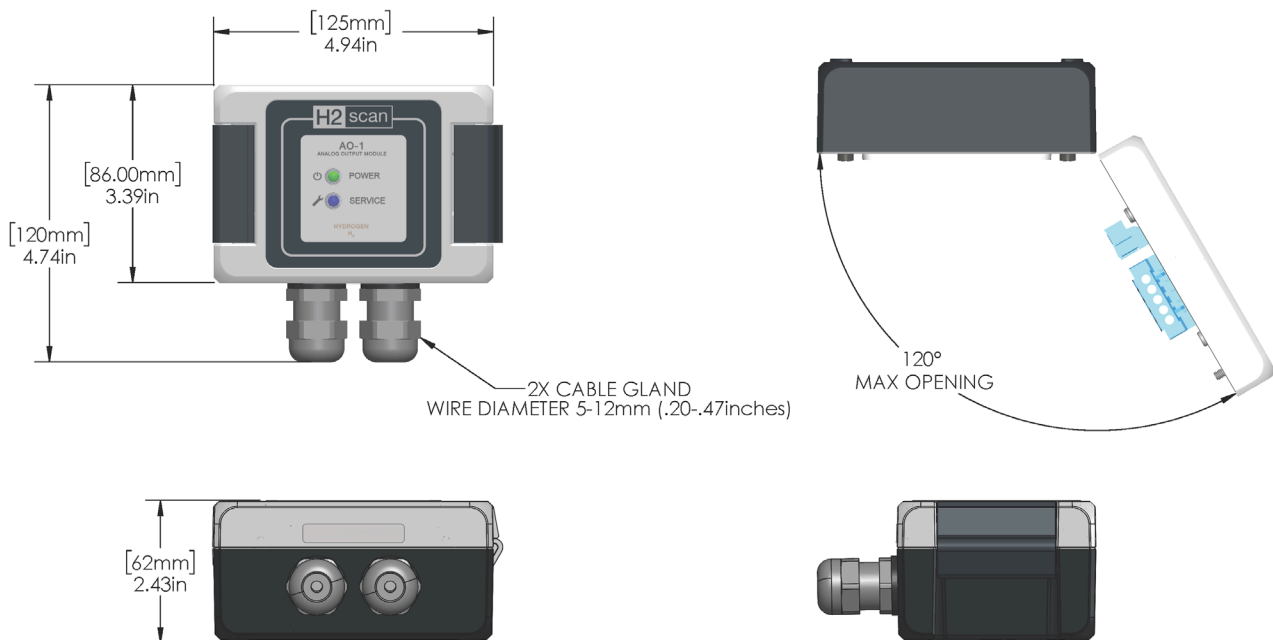

**Figure 1: GSAO-1 Dimensions**

## 2.4 Enclosure Sealing

There are three main sealing components within the GSAO-1 Analog Output Module system: the cover gasket seal, the window seal, and the cable gland seal.

The gasket sealed precision die-cast enclosure of the GSAO-1 Analog Output Module has a sealed chemically strengthened glass window and is provided with cable gland fittings. The combination provides a system that is rated for IP68 for water and dust ingress. The cable gland fittings can be replaced by the customer with 1/2” conduit gland fittings, but this may impact the ingress protection rating. H2scan offers adaptors for metric M20. Only properly installed IP66 or better rated conduit gland fittings are supported by H2scan. Failure to use proper

gland fitting solutions may void the product warranty. Use of conduit fittings rated less than IP68 will decrease the rating of the system to the rating of the conduit fittings used.

## 2.5 Electrical Features

A cable is required for connecting the GSAO-1 Analog Output Module to the GRIDSCAN 5000 Hydrogen Sensor. The required cable has a single 4-pin M12 connector for connection at the GRIDSCAN 5000 Hydrogen sensor for power and communications. This connector and cable should be rated for IP66 or better to match the sensor installation conditions. The other end of the cable has individual wire leads for connection to the GSAO-1 module. (see wiring instructions section [8.3.2](#))

Additionally, the customer must supply DC power to the GSAO-1 module and take the analog signal out to their data system. This cable should be a four conductor cable with wire size up to 4 mm (12 AWG) for the following:

- 2-wire DC power input of 9 to 48 volts, 13 watts (24 VDC or 48 VDC Power Supply is recommended)
- 2-wire current loop for the 4-20 mA output. Powered by GSAO-1 with the following impedance requirements:
  - 0 Ohm minimum load.
  - 250 Ohm recommended load.
  - 500 Ohm maximum load.

It is recommended that all cables be shielded with a drain wire grounded at one end.

## 3 Specifications

**Table 1: GSAO-1 Analog Output Specifications**

Parameter	Value			Units
	Minimum	Nominal	Maximum	
Normal Current	4		20	mA
High Current	20		24	mA
High Current Service	24			mA
Low Current Service	0		4	mA
Accuracy	±0.04 mA			
Media (Gas or Oil)	Auto-detected from the GRIDSCAN 5000 Hydrogen sensor			
Scaling of 4 mA	Equal to 0 ppm of Hydrogen			
Scaling at 20mA	Selectable to Equal:			
	<i>Oil Phase</i>		<i>Gas Phase</i>	
	100 ppm (Default)		2,000 ppm (Default)	
	250 ppm		5,000 ppm	
	500 ppm		10,000 ppm	
	1,000 ppm		20,000 ppm	
	2,000 ppm		40,000 ppm	
	5,000 ppm		100,000 ppm	
Calibration Interval	No periodic calibration of GSAO-1 is required			

**Table 2: GSAO-1 Operating Conditions**

Parameter	Value			Units
	Minimum	Nominal	Maximum	
<b>Environment – Ambient</b>				
Operating Temperature	-40	25	70	°C
Storage Temperature	-40		85	°C
Ingress Protection	IP68 (IEC 60529) with provided cable gland fittings			
Humidity	0 to 100% RH, condensing			
Altitude	Up to 2000 m (6560 ft)			
<b>Mechanical</b>				
Vibration	3-axis Sinusoidal, Wideband and Random (IEC 60068-2-6 table C.2, IEC 60068-2-64 paragraph A.2, category no. 2, IEC 61373: 2010 Cat 1B section 9)			
Shock	30g, shock duration 18ms (IEC 60068-2-27)			
<b>Electrical</b>				
Voltage Input, Absolute Maximum	8.1	24	52.8*	VDC
Power Consumption			13**	W

\* Do NOT exceed maximum voltage

\*\* Includes power to the GRIDSCAN 5000 Hydrogen Sensor

### 3.1 Certifications

List of standards:

- Capability Damped Oscillatory IEC 61000-4-12
- Conducted RF IEC 61000-4-6: 2009
- Surge IEC 61000-6-5; IEC 61000-4-5: 2006
- Radiated RF IEC 61000-6-5; IEC 61000-4-3: 2010
- Electrostatic Discharge IEEE C37.90.3: IEC 61000-4-2: 2009
- Dielectric Strength IEC 60255-2: 2000; IEEEC37.90-2005
- Impulse IEC 60255-5: 2000
- Fast Transient; Burst IEC 60255-22-4: 2008; IEC 61000-4-4: 2011
- Conducted Emissions EN 55011 Class A
- Radiated Emissions EN 55011 Class A
- Magnetic Field IEC 61000-4-8: 2010
- Voltage Dips and Interrupts IEC 61000-4-11: 2004
- Ingress Protection IEC 60529: 1986/AMD2:2013/Cor1:2019
- Humidity and Corrosion Resistance C5M Marine Rated; IEC 60068-2-11, DIN EN ISO 12944
- Vibration – Sinusoidal IEC 60068-2-6 Table C2; IEC 60068-2-64 Par A.2
- Vibration – Shock and Bump IEC 60068-2-27; 30g @ 18ms
- Electrical Safety EN 61010-1:2010 (including 60255-2 Dielectric Strength)

Directives

- Restriction of Hazardous Substances RoHS 3 Directive 2015/863 plus Category 11
- REACH EC No.197/2006
- Dodd- Frank Conflict Mineral Compliance Dodd – Frank Section 1502

## 4 Product Overview

### 4.1 Front View Features:

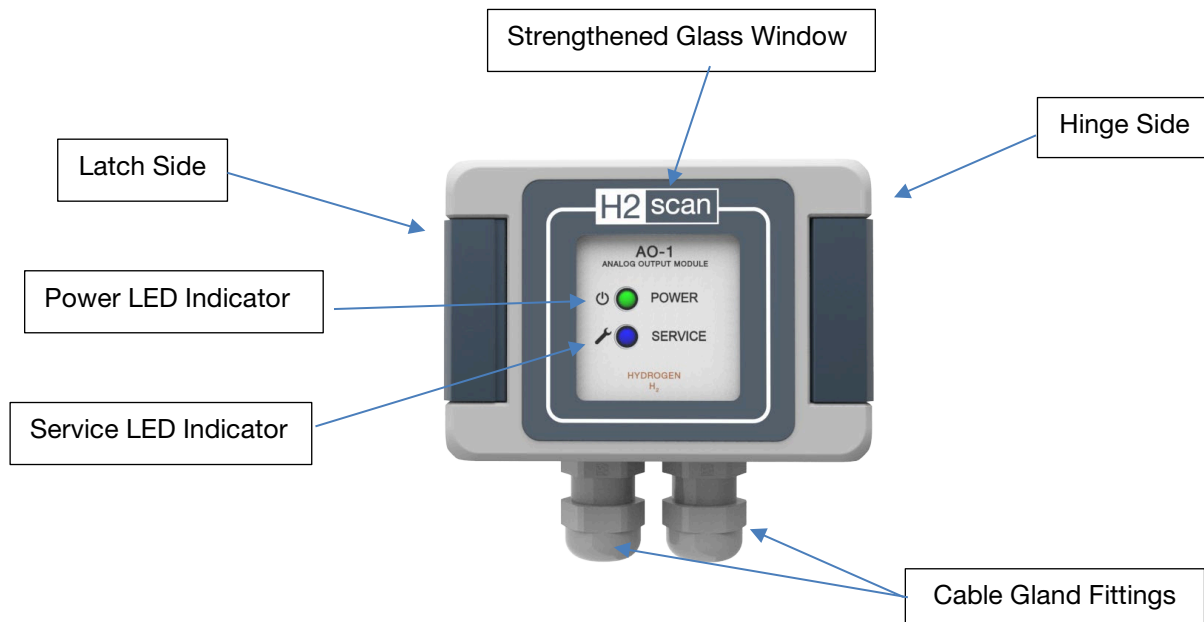

Figure 2: GSAO-1 Front View Features

### 4.2 Open View Features:

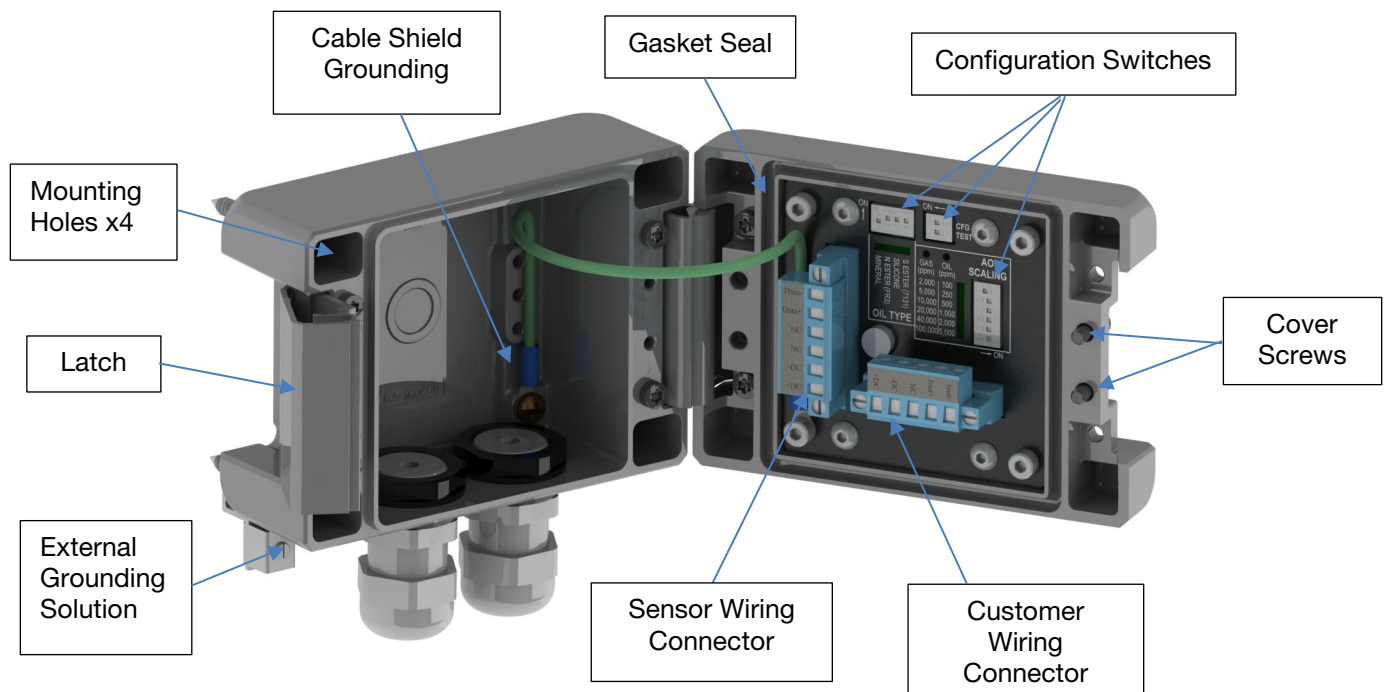

Figure 3: GSAO-1 Open View Features

## 5 Labeling

The product label is a permanent externally mounted label containing the manufacturer or distributor name, model number, the manufacturer's part number, a serial number, the date of manufacture, and compliance marking for CE and FCC.



Figure 4: GSAO-1 Product Label

## 6 Enclosure Access

When looking at the front panel of the GSAO-1 unit, the latch is located on the left side of the enclosure. From the front, the latch will release and will swing from the front to the left. This exposes the cover screws that compress the cover to the base. These screws are held captive in the cover and will not fall out. Using the supplied 3mm hex L-Key, loosen the cover screws until they are no longer locking the cover to the base. The cover will then easily swing to the right.



Figure 5: GSAO-1 Closed View for Access

*GSAO-1 Opened View*



**Figure 6: GSAO-1 Open View for Access**

To close the cover, reverse the steps making sure to tightly secure the cover screws. This should be approximately 1.13 N\*m (10 in\*lbf). Failure to tighten the cover screws can compromise the sealing of the GSAO-1 unit and may compromise the IP rating of the system.

## 7 Mounting

The GSAO-1 can be easily mounted to panels and plates. Included with every unit in the Quick-Start Guide is a 1:1 template for easily locating the appropriate mounting hole locations. The included stainless-steel machine screws require that pilot holes be drilled using a 3mm (1/8”) drill bit. It is recommended that pilot holes be marked and drilled prior to mounting the GSAO-1 module to generate the most robust and secure mounting.

Install the unit with the provided #10 stainless steel screws to approximately 6.3 N\*m (56 in\*lbf).

For external grounding of the GSAO-1 module, the grounding kit generates metal-to-metal contact through the mounting screws. The grounding clip is installed when mounting the GSAO-1 unit in conjunction with the provided star washers. Specifically for the mounting of the grounding clip, a star washer should be installed on the screw that is inserted into the mounting hole AND an additional star washer should be installed between the enclosure base and the grounding clip. Use the last remaining star washer on the adjacent corner to level the mounted unit.

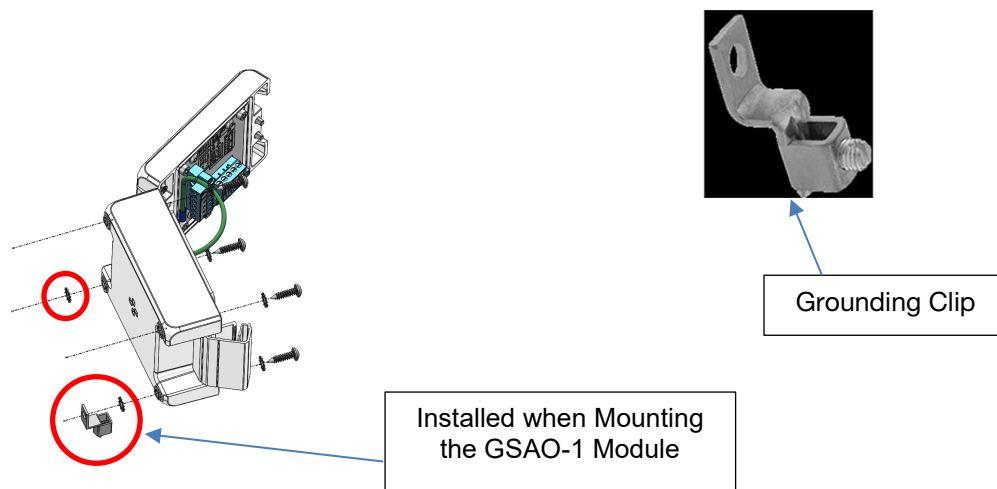

**Figure 7: GSAO-1 External Grounding Solution**

Alternatively, the GSAO-1 module can be mounted using DIN rail, Unistrut, or wedge anchors into concrete or masonry.

The customer is responsible for properly grounding the GSAO-1 module.

It is recommended that the GSAO-1 be mounted within  $\pm 10^\circ$  of level.

## 8 Electrical Interface

All electrical connections to the GSAO-1 Analog Output Module are supplied through two multi-conductor cables. One cable supplies power to, and exchanges data with, the GRIDSCAN 5000 Hydrogen Sensor. The other cable is supplied by the end user to provide DC power to the GSAO-1 and to take the analog output current loop to their control system.

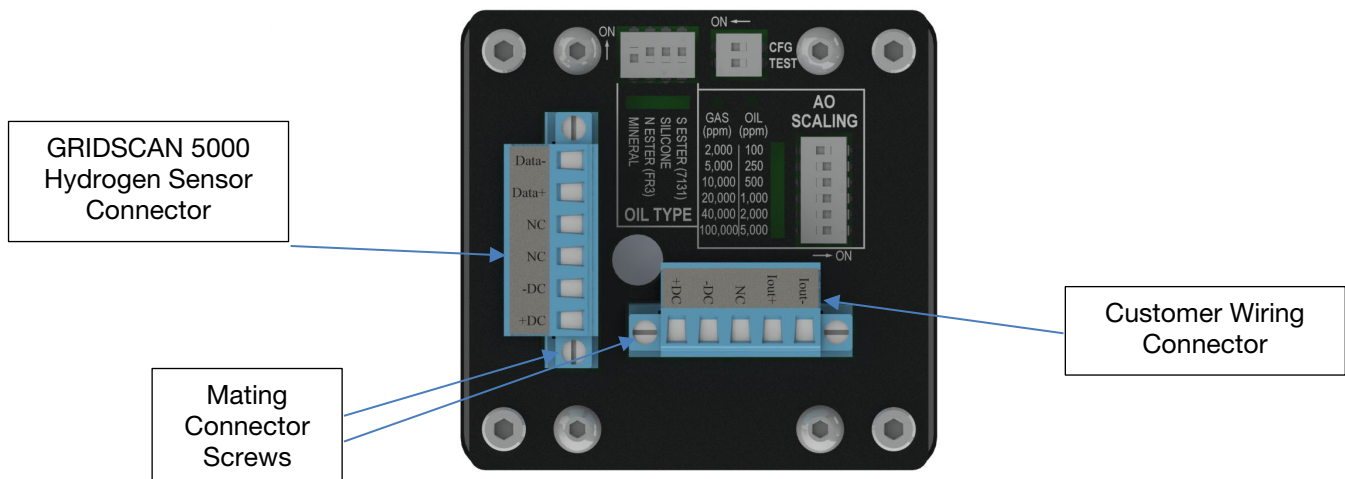

**Figure 8: GSAO-1 Electrical Connectors**

Each connector is comprised of two pieces; one that is mounted to the printed circuit board assembly (PCBA), and a mating connector that is secured to the PCBA connector with two captive screws. Due to keying of the mating connectors, they can only be plugged into the PCBA portion of the connector one way. Each of the mating connectors is clearly labeled with the wiring locations on the mating connector.

### 8.1 Gland Fittings

The GSAO-1 Analog Output Module is supplied with two IP68 rated cable gland fittings that accommodate 5 mm to 12 mm (0.20" to 0.47") Outside Diameter jacketed cables.

If it is desired to utilize conduit to route cables to and from the GSAO-1, the cable gland fittings can be replaced by standard 1/2" conduit gland fittings without modification to the enclosure. The IP rating of the GSAO-1 is dependent upon the rating and construction of the conduit gland fittings. It is recommended that only IP66 or better rated conduit gland fittings be used. Use of lower rated fittings can result in damage to the GSAO-1 unit and can void the warranty.

Do not install more than one cable per cable gland fitting. Installing more than one cable per gland fitting will compromise the IP rating of the fitting and GSAO-1 module.

If the cable gland fittings are replaced with conduit gland fittings, the IP rating is considered to be IP 66 or less regardless of conduit gland rating. If conduit gland fittings are used, the GSAO-1 should not be mounted where it will be submerged. Doing so voids the warranty.

Modification of the GSAO-1 enclosure to increase the size of the gland fitting ports is not recommended. It can compromise the IP rating of the system and can void the warranty.

## 8.2 Cables

The cable supplied for customer connection should be rated for the environmental conditions it will be used in. A suitably rated cable assembly is required for most field applications.

Cable recommendations are:

- 4 Conductor, 1 to 4 mm (18 to 12 AWG) wire
- Shielded cable with drain wire is recommended
- Outdoor, waterproof, and UV rated jacket

The customer cable shield drain wire should only be grounded at the power supply end and **NOT** in the GSAO-1 Module.

An earth ground conductor should NOT be added to the power and signal cable brought to the GSAO-1 Analog Output Module. Induced currents can affect the operation of the GSAO-1 Module and can cause interference on the analog signal.

The cable used to connect to the GRIDSCAN 5000 Hydrogen sensor is an orderable option available in various lengths. If the cable is not ordered from H2scan, it should be rated for the environmental conditions it will be used in. A suitably rated cable assembly is required for most field applications.

If the cable is not sourced from H2scan, below are the cable recommendations:

- 4-pin M12 Female molded connector
- IP68 rated connector (or applicable IP rating)
- 4 conductor 1mm (18 AWG) wire
- Shielded cable with drain wire is recommended
- Outdoor, waterproof, and UV rated jacket

For cables not ordered from H2scan with the GSAO-1 or GRIDSCAN 5000 Hydrogen Sensor system, the key (notch) location and pin numbers are shown below.

**Table 3: GRIDSCAN 5000 Hydrogen Sensor Pin Out**

Pin	Signal Name	Wire Color
1	DC power	Brown
2	DC ground	White
3	RS485 Data+	Blue
4	RS485 Data-	Black

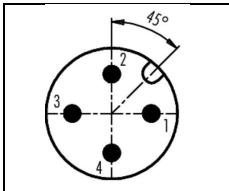

This view is looking at the connector on the GRIDSCAN 5000 Hydrogen Sensor. The wire colors of the cable listed above are not standard and should not be confused with AC power standards. Do NOT connect the GSAO-1 to AC power. If the GSAO-1 is connected to AC power, permanent damage will occur and will void the warranty.

## 8.3 Wiring Connections

On the mating connector that plugs into the PCBA, there are openings where the stripped wires are inserted and screws, that when tightened, secure the wires into the connector slots. The customer wiring connector has five wiring slots. The GRIDSCAN 5000 Hydrogen sensor connector has six wiring slots.

Wires between 1mm (18 AWG) and 4 mm (12 AWG) can be used. Smaller or larger wires are not recommended or supported.

Bare stripped wire should be used. Tinning is not recommended.

Do NOT unplug or plug wiring connectors when the system is energized.

### 8.3.1 Earth Grounding the GSAO-1 Module

An earth ground is required to be connected to the case of the GSAO-1 Analog Output Module. It should be added in conjunction with the mounting hardware. (See Section 7)

With the grounding clip securely installed with the GSAO-1 mounting, insert the bare grounding wire into the clip and tighten the set screw.

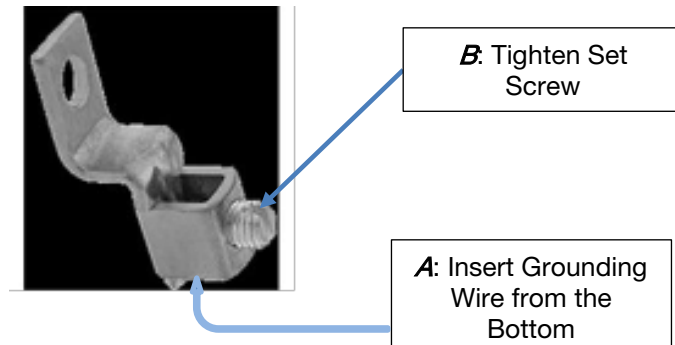

**Figure 9: GSAO-1 External Grounding Connector**

### 8.3.2 GRIDSCAN 5000 Hydrogen Sensor Wiring Connections

After connecting the cable to the GRIDSCAN 5000 sensor, route the cable to the GSAO-1. Secure cable as necessary. Trim the cable to length so that there will be approximately 160 mm (6.5 inches) inside of the GSAO-1 module when assembled.

The standard H2scan multi-conductor cable has four conductors that are 1 mm (18 AWG) and a foil shield with a drain wire.

The cable outer jacket should be stripped to 152 mm (6 inches).

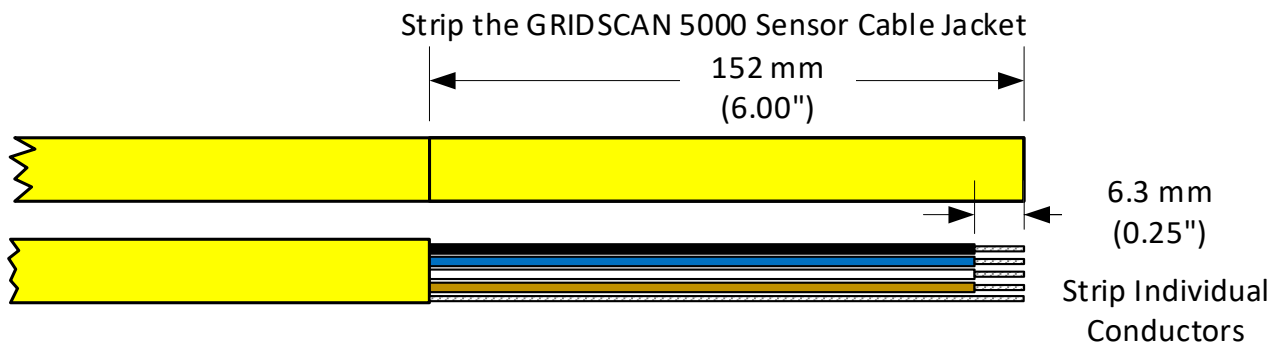
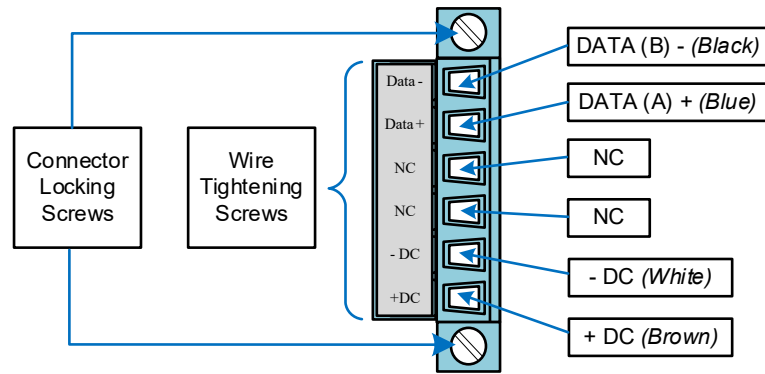

**Figure 10: GRIDSCAN 5000 Cable Stripping**

The ends of the conductors should be stripped 6 mm (¼ inch) from the end. Do not tin or solder the bare metal conductors.

After all wires are stripped, insert the sensor cable through the right gland fitting on the GSAO-1 enclosure closest to the hinge so that 10 mm (½ inch) of the cable jacket is visible inside the enclosure above the gland fitting. Securely tighten the gland fitting to the cable using an adjustable wrench. 0.28 N\*m (2.5 in\*lb)

Insert each wire into the slotted opening on the mating connector in accordance with the label on the connector and as illustrated in the diagram below. Insert only the bare wire and not the insulated portion of the conductor. Secure the wire by tightening the corresponding screw using the provided flat blade screwdriver. 0.5 N\*m (4.42 in\*lb) Do not overtighten or strip the screws. After tightening, gently pull on the wire to ensure it is securely connected. Repeat until all wiring connections have been made.

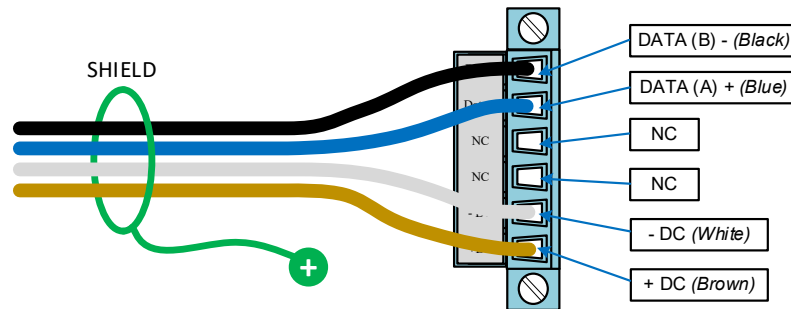

**Figure 11: GRIDSCAN 5000 Hydrogen Sensor Wiring Connector**

View of mating connector as mounted on the circuit board.

In the example shown in *Figure 12: GRIDSCAN 5000 Hydrogen Sensor Connector with Wires*, the Black wire is connected to DATA (B) -, the Blue wire is connected to DATA (A) +, the White wire is connected to - DC, and the Brown wire is connected to + DC.

Color coding should be confirmed if not using a cable supplied by H2scan.



**Figure 12: GRIDSCAN 5000 Hydrogen Sensor Connector with Wires**

The drain wire for the cable shield should be trimmed to length and secured to one of the multiple locations inside of the enclosure using a provided grounding screw. 1.13 n\*m (10 in\*lb)

After all wires are securely connected, plug the mating connector into the PCBA and secure with the two connector locking screws. 0.4 N\*m (3.54 in\*lb) Do not over-tighten.

### 8.3.3 Customer Wiring Connections

The multi-conductor cable used by the customer should have conductors that are between 1 mm and 4 mm (18 AWG and 12 AWG) and should have a minimum of four conductors and a shield with a drain wire. Two conductors should be used for DC power, and two for current loop analog output.

After routing the cable to the GSAO-1 installation, trim any excess cable so that approximately 210 mm (8.5 inches) of cable will be inside the GSAO-1 module.

The cable outer jacket should be stripped to 203 mm (8 inches).

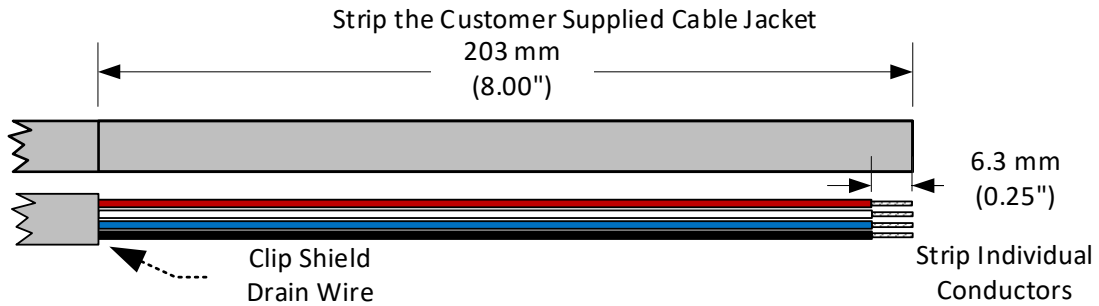
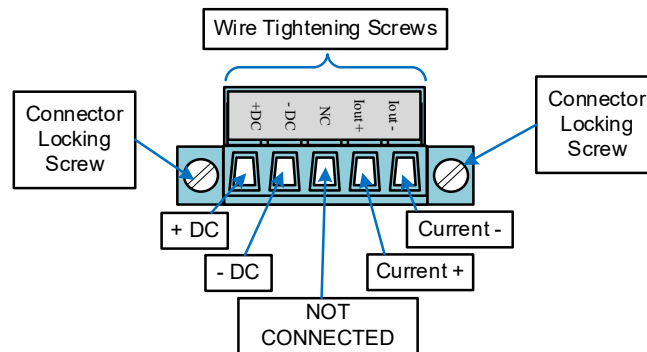

**Figure 13: Customer Cable Stripping**

The ends of the conductors should be stripped 6 mm (¼ inches) from the end. Do not tin or solder the bare metal conductors.

After all wires are stripped, insert the cable through the left gland fitting on the GSAO-1 enclosure so that 10 mm (½ inch) of the cable jacket is visible inside the enclosure above the gland fitting. Securely tighten the gland fitting to the cable using an adjustable wrench. 0.28 N\*m (2.5 in\*lb)

Insert each wire into the slotted opening on the mating connector in accordance with the label on the connector and as illustrated in the diagram below. Insert only the bare wire and not the insulated portion of the conductor. Secure the wire by tightening the corresponding screw using the provided flat blade screwdriver. 0.5 N\*m (4.42 in\*lb) Do not overtighten or strip the screws. After tightening, gently pull on the wire to make sure that it is securely connected. Repeat until all wiring connections have been made.



**Figure 14: GSAO-1 Customer Wiring Connector**

View of the customer mating connector as it is mounted on the circuit board.

In the example shown in *Figure 15: GSAO-1 Customer Connector with Wires*, the Red wire is connected to +DC, the Black wire is connected to – DC, the White wire is connected to Current +, and the Blue wire is connected to Current -.

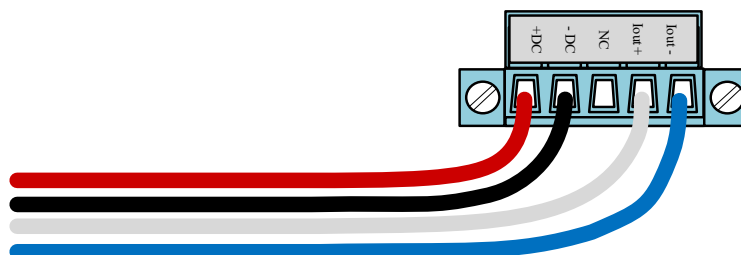
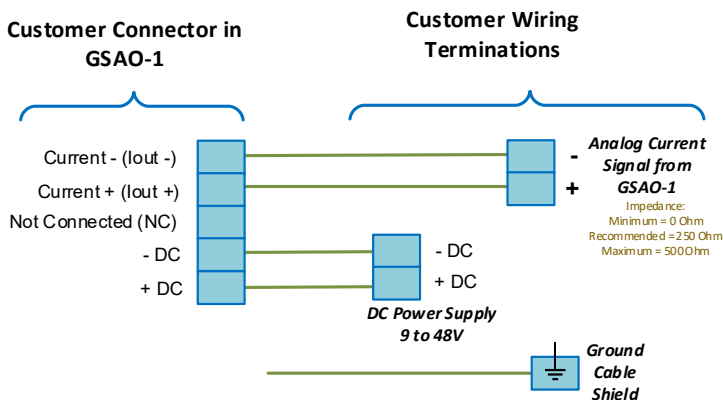

**Figure 15: GSAO-1 Customer Connector with Wires**

After all wires are securely connected, plug the mating connector into the PCBA and secure with the two connector locking screws. 0.4 N\*m (3.54 in\*lb) Do not over-tighten.

### 8.3.4 Customer Wiring Terminations (Not at GSAO-1)

With the customer cable properly terminated in the GSAO-1, the other end must be terminated in the control panel or junction box. Please refer to *Figure 16: Customer Wiring Termination (Not at GSAO-1)* for proper wiring terminations.



**Figure 16: Customer Wiring Termination (Not at GSAO-1)**

The analog signal is to be terminated as illustrated to ensure proper functionality. The impedance of the current loop should ideally be 250 Ohms and no more than 500 Ohms.

The power supply should be connected as illustrated to ensure proper functionality of the GSAO-1.

The cable used should have a shield and drain wire. This drain wire should be grounded at the customer termination end of the cable and NOT inside of the GSAO-1 module.

### 8.3.5 Wire Dressing

With both cables installed, the wires should be dressed so that the DIP switches and internal LEDs can be seen, and so that the cover can be closed without pinching any of the wires. The wires are to be dressed across the hinge side of the enclosure using the supplied cable ties as shown in *Figure 17: GSAO-1 Cable Wire Dressing*. After the cable ties are in place, trim the excess portion of the cable tie with wire clippers.

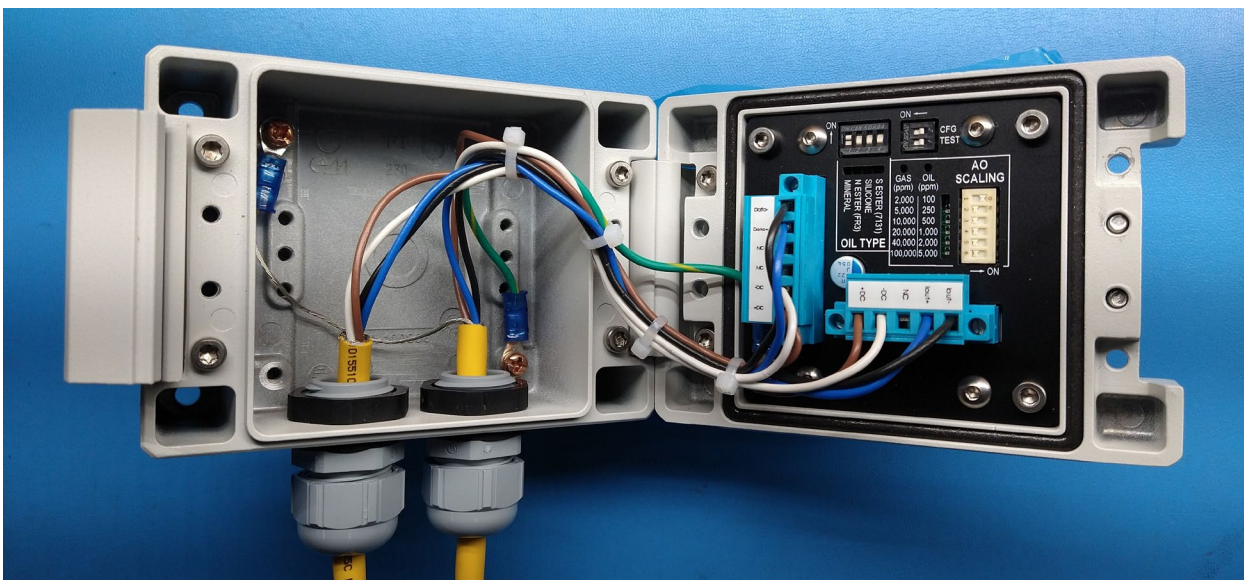

**Figure 17: GSAO-1 Cable Wire Dressing**

## 8.4 Power Supply

It is recommended that the GSAO-1 be powered by an industrial grade fixed output power supply that meets the following specifications:

- DC voltage output
- Output Voltage: 9, 12, 15, 24, 30, 36 or 48 VDC nominal
- Output power: 13 Watts minimum

24 VDC or 48 VDC Power Supply is recommended.

The drain wire on the shielded customer cable used to bring power and signal to the GSAO-1 Analog Output Module should be earth grounded only at the power supply end of the cable and **NOT** in the GSAO-1 Module.

## 9 Operation

### 9.1 Startup

After connecting the cables and applying power from the supply, the GSAO-1 delivers power to the GRIDSCAN 5000 Hydrogen Sensor. Both the GSAO-1 and sensor will then execute startup sequences. The GSAO-1 boots within 30 seconds.

The GRIDSCAN 5000 sensor can take 30 minutes to 16 hours before the sensor provides accurate data. The following operations are done during the sensor startup sequence:

- Power on system self-test
- Restore configuration settings from non-volatile memory
- Start measuring oil temperature and Hydrogen
- Runs auto-calibration sequence to stabilize sensor as needed (sensor may show initial value before auto-calibration is complete)

Please refer to the GRIDSCAN 5000 Hydrogen Sensor Manual (p/n 9000177) for more detailed information.

Upon startup, the GSAO-1 initiates its firmware and attempts to establish communications with the Hydrogen sensor. The status is indicated with the front panel LEDs.

## 9.2 Front Panel LEDs

The GSAO-1 Analog Output Module has two front panel LEDs; the **Green** LED indicates power and communication status to the Hydrogen sensor. The **Blue** LED indicates service conditions for either the GSAO-1 module or the Hydrogen sensor.

**Table 4: GSAO-1 Front Panel LED Indications**

Condition	Green LED	Blue LED
No Power	OFF	OFF
Initial Power ON	Flashing *	Flashing *
GSAO-1 Communicating with Hydrogen Sensor (Normal Condition)	ON	OFF
GSAO-1 Service Condition	ON	ON
Hydrogen Sensor Service Condition		
Configuration Mode		

\* On initial power on, the flashing rate for the **Blue** and **Green** LEDs is once per second.

## 9.3 Analog Output

The GSAO-1 analog output is expressed as a 4-20 mA signal. The following table indicates functionality:

**Table 5: GSAO-1 Analog Output Indications**

Current	Condition	Service
0 mA	No cable to Hydrogen Sensor or Power Off	N/A
2 mA	Hydrogen Sensor not ready for Operation	
3 mA	GSAO-1 or Hydrogen Sensor Error <sup>†</sup> or GSAO-1 in Configuration Mode	Yes
4-20 mA	Normal Operation	No
12 mA	TEST Mode	Yes
20-24 mA*	Scaling Error Data may not be accurate but trends properly	Yes

<sup>†</sup> For General GSAO-1 or Hydrogen sensor errors, the **Blue** LED will blink once every 12 seconds.

\* If the output current is greater than 20 mA but less than 24 mA, the system will continue to operate and report data as normal. The service LED illuminates without blinking to indicate that the scaling needs to be changed.

## 9.4 Service Conditions

For service conditions for the GRIDSCAN 5000 Hydrogen Sensor system, please refer to the Operating Manual (p/n 9000177).

The following Conditions will cause the GSAO-1 Analog Output Module to display service condition and turn on the **Blue** LED.

**Table 6: GSAO-1 Service Conditions**

Condition	Action Necessary to Remedy
The analog output signal is greater than 20mA, but less than 24 mA	Re-scale the analog output level to bring the signal down to normal current range  <i>The system will continue to operate and report data, but it may not be accurate. Trend data will be appropriate.</i>
The calculated analog output signal is greater than 24 mA	Re-scale the analog output level to adjust the signal down to normal current range
The serial number detected from the associated GRIDSCAN 5000 Hydrogen Sensor does NOT match the sensor serial number stored in the GSAO-1 Module	Enter configuration mode, set a new valid configuration, and exit configuration mode.
The GSAO-1 Module is in Configuration Mode	Change the CFG switch setting to enable operational mode
The GSAO-1 has an invalid configuration	Re-enter configuration mode, make a valid configuration with one oil type and one analog output scaling level switch selected and exit configuration mode
The GSAO-1 loses communication to the Hydrogen Sensor	The system will automatically retry to establish communications. If this becomes problematic, check wiring and grounding.  If the problem persists, contact technical support at <a href="mailto:help@h2scan.com">help@h2scan.com</a> .

## 10 Configuration Mode

Warning - When changing switch settings, the use of the tip of the provided golf tee is recommended with a minimum level of force. Use of other tools or too much force can cause damage to the switches or prevent full actuation. Damage to the switches can affect the operation of the GSAO-1 module and may void the warranty.

The GSAO-1 Analog Output Module has a configuration mode where the oil type can be changed, the scaling of the analog output can be changed, and the analog output can be tested. The configuration mode can be entered, executed, confirmed, and exited using the DIP switches.

Re-booting or power cycling is not required to enable the new configuration. Switching the “CFG” switch OFF activates the new configuration.

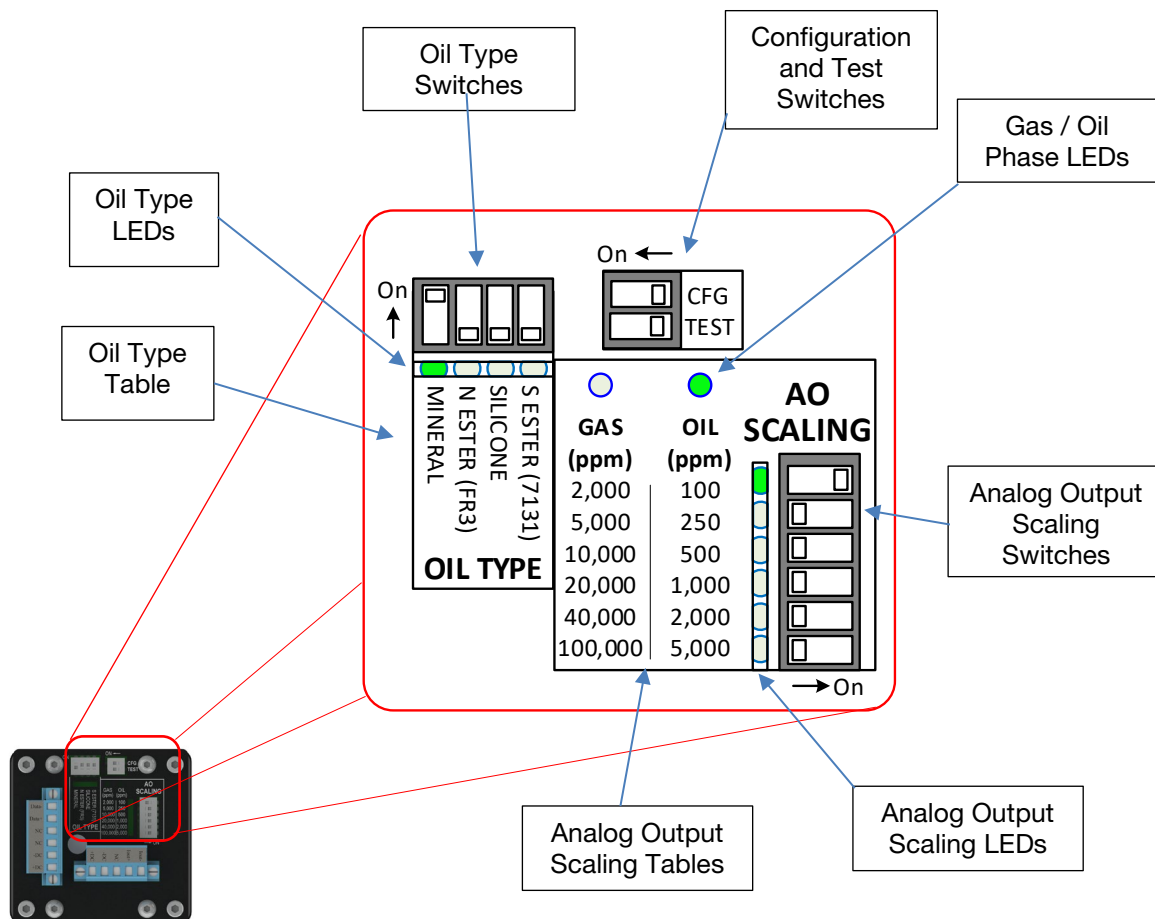

**Figure 18: Configuration Overview**

If the GSAO-1 unit is not in configuration mode, the LEDs for Gas / Oil, analog output scaling, and oil type indicate the configuration that is stored within the unit. The switch positions may not indicate the current settings. To ensure proper configuration, follow the steps in Section 10.3. The configuration within the unit is stored and used from non-volatile memory.

### 10.1 Gas Phase or Oil Phase

When the GSAO-1 communicates to the GRIDSCAN 5000 Hydrogen sensor, the sensor communicates whether it was factory configured and calibrated for gas phase operation or oil phase operation. The LED above the scaling table illuminates to indicate gas phase or oil phase and also indicates which table should be used for scaling. This is done regardless of whether the unit is in configuration mode or operational mode. There is no way for the user to change this parameter. It is factory configured. The only way to change this is to replace the GRIDSCAN 5000 Hydrogen Sensor with the desired configuration.

If the sensor is gas phase calibrated, the LED above “GAS” will be illuminated. Additionally, no oil type LED’s will be illuminated, and oil types cannot be changed or selected in configuration mode. (See section 10.3)

### 10.2 Changing the Sensor System

When the GSAO-1 communicates to the GRIDSCAN 5000 Hydrogen sensor, the sensor communicates its serial number. The GSAO-1 compares the sensor serial number with the one that is stored as part of the configuration in non-volatile memory. Normal operation will commence if the serial number is the same.

However, if the serial number is different, the GSAO-1 will enter a service condition. This is indicated by the Blue LED blinking 3 times every 12 seconds. It is assumed that if the sensor is changed or the GSAO-1 is relocated to another installation site, that the configuration would need to be changed. This forced re-configuration will be observed upon the initial installation as the factory set serial number will differ from the sensor serial number being accessed in the field.

## 10.3 Configuration Mode

### 10.3.1 Entering Configuration Mode

With the GSAO-1 powered on, enable the configuration mode by using the provided golf tee to change the switch at top center labeled “CFG” from the right to the left. When this is done properly and after a brief delay, the LEDs will be illuminated in sequence from top to bottom, left to right to indicate that the unit is in configuration mode. The LEDs will be illuminated starting with “MINERAL” in the oil type section, going to the right through the “GAS | OIL” LEDs, and down through the scaling LEDs with the “100,000 | 5,000” LED being the last to illuminate. The LEDs will then change to reflect the switches that are selected or turned ON and the proper media type (GAS or OIL).

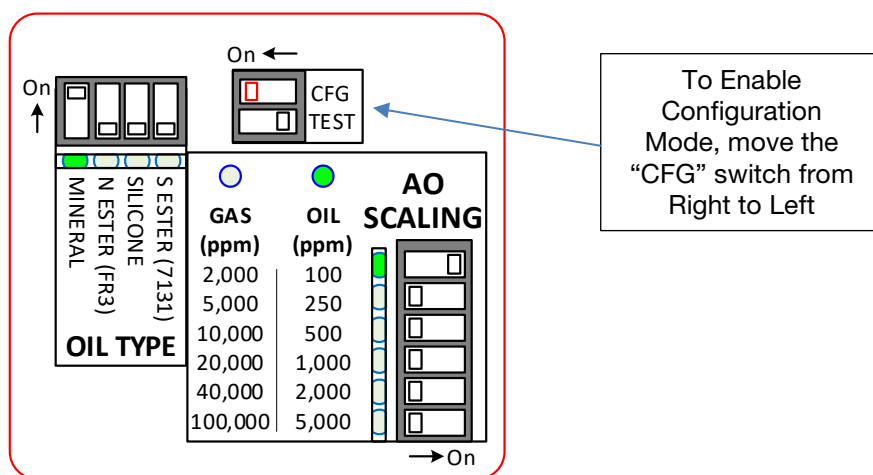

**Figure 19: Enabling Configuration Mode**

When in Configuration mode, the analog output is set to 3 mA and the Blue service LED on the front panel is turned ON and will blink once every 12 seconds.

While in the configuration mode, the user can change the oil type, change the analog output scaling, or test the analog output.

When selecting oil type or analog output scaling, only one switch for each can be selected for a valid configuration. If no oil type or scaling switches or more than one oil type or scaling switches are selected, it will NOT generate a valid configuration. If the “CFG” switch is turned OFF with an invalid configuration, the erroneous configuration will not be stored, and the unit will revert back to the last valid configuration. This will generate a service condition that is indicated by the LEDs. If invalid switches are set, the LEDs next to the invalid switches will flash once per second to indicate where the error in configuration is. If no switches are set in either the oil type or scaling blocks, all the LEDs in the invalid block will flash once/second to indicate where the configuration error is located. For all invalid configuration errors, the Blue LED will blink six times every 12 seconds.

### 10.3.2 Test Mode

Immediately below the “CFG” switch is a “TEST” switch. When the GSAO-1 is in configuration mode, it automatically sets the analog output to 3 mA. While in configuration mode, if the “TEST” switch is moved from right to left using the provided golf tee, the analog output will change to **12 mA**. The “CFG” switch must be enabled and moved to the left before placing the GSAO-1 into TEST mode.

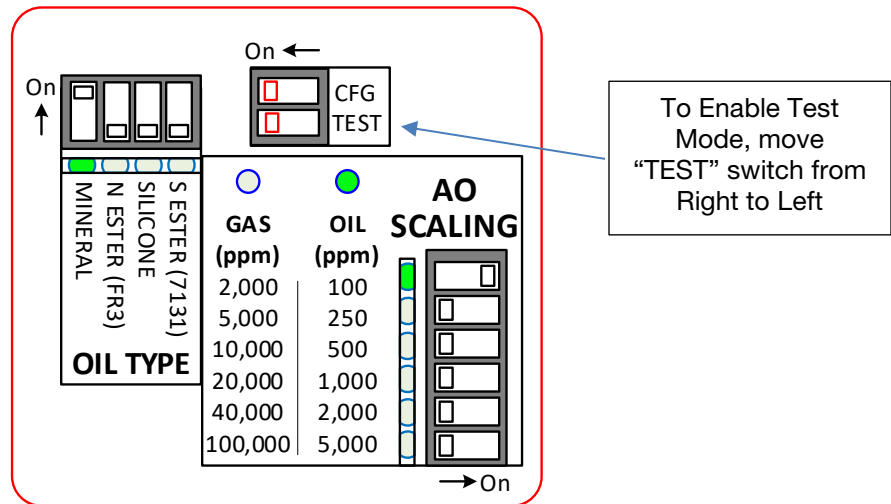

**Figure 20: Enabling TEST Mode**

When testing is complete, the switch should be moved from the left to the right position and the analog output will return to 3 mA.

The “TEST” switch should be turned OFF before turning the “CFG” switch OFF.

### 10.3.3 Oil Type Selection

If the GRIDSCAN 5000 Hydrogen sensor that is connected to the GSAO-1 Module is configured for oil operation, and the LED above the “OIL (ppm)” in the scaling table is illuminated, the oil type is active and the configured oil type is indicated by the LED under oil type. If “GAS (ppm)” is indicated, the oil type selection is not active and cannot be configured.

There are four oil types available: Mineral, Natural Ester (FR3), Silicone, and Synthetic Ester (7131). The default mode is for Mineral oil. The LED below the switches indicates which oil type is configured.

When the GSAO-1 is set to configuration mode, the oil type can be changed by moving the switch above the desired oil type from the bottom to top position using the provided golf tee. The switch for the previously selected oil type should be then moved from the top to the bottom position. The LED below the selected oil type will then be illuminated to confirm the selection.

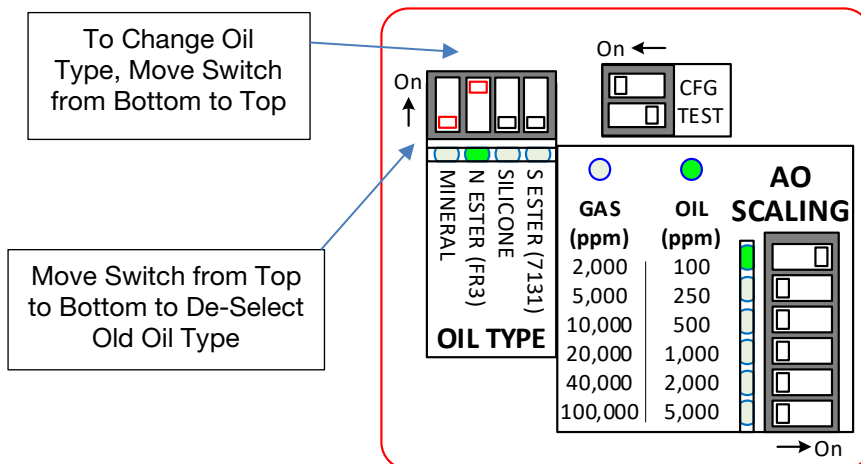

**Figure 21: Example of Changing Oil Type to “N ESTER (FR3)”**

Figure 21: Example of Changing Oil Type to “N ESTER (FR3)” shows an example of changing the oil type. The “CFG” switch is turned ON, the “MINERAL” switch is turned OFF, the “N ESTER (FR3)” switch is turned ON, and the LED below the switch for “N ESTER (FR3)” is illuminated.

While in configuration mode and setting oil type, all switches that are selected and turned ON will have their associated LED illuminated. If no switches are selected, no LEDs will be illuminated. If more than one switch is selected, all of their LEDs will be illuminated. A valid configuration requires that only one switch be selected and one LED illuminated.

#### 10.3.4 Analog Output Scaling

Every installation is different. They have different levels of Hydrogen ranging from zero to many thousands of ppm. The GSAO-1 supports improved accuracy by providing a method to scale the analog output range. The scaling of the analog output should be set to reflect the concentrations reported in the field allowing for increases in hydrogen without exceeding the specified range.

Specifically, zero ppm is set to be reflected as 4 mA. This cannot be changed. However, the full scale of the output, the 20 mA setting is configurable. As most installations have little or no hydrogen, but have a high potential to generate hydrogen, the default setting is 100 ppm in the oil phase and 2,000 ppm in the gas phase.

Note: In a sealed transformer with a gas space, the hydrogen concentration in gas is approximately 20 times the concentration in oil.

If the Hydrogen concentrations encountered at the installation are higher than the default values, it is recommended that the analog output scaling be changed to reflect the actual concentrations being detected, allowing ample range for the detection of increased concentrations.

The GSAO-1 Analog Output Module has the ability to report an analog output signal up to 24 mA. However, signals between 20 mA and 24 mA exceed the selected 4-20 mA scale and the GSAO-1 should be reconfigured for the appropriate scale. The Hydrogen sensor and GSAO-1 will continue to operate and report data, but the Blue service LED on the front panel will be illuminated without blinking to indicate the error. Rescaling the output will clear this error.

If the output signal is calculated to be in excess of 24 mA, the system will change the output to 3 mA and will have the Blue service LED on the front panel illuminated continuously, and the analog output scaling LEDs will flash ON and OFF. The system will continue to check the output. If it drops below 24 mA, the system will again reflect the Hydrogen concentration being reported. If the scaling is changed to bring the reported signal within proper range, the system will recover and no longer indicate the service error.

To change the analog output scaling, the system must be in configuration mode. The table to use is indicated by the LED indicating either "GAS" or "OIL" phase operation.

The range can be changed by moving the switch next to the desired range from the left to the right position using the provided golf tee. The previously selected range needs to be de-selected by moving its switch from the right to the left position. Only one scaling range selected is considered valid. The validly selected range will be indicated by the illumination of the LED next to the selection.

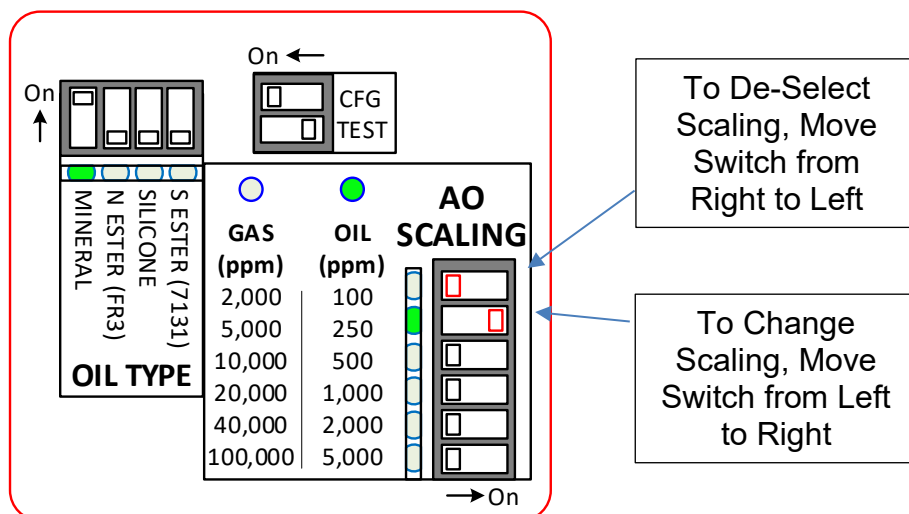

**Figure 22: Example of Changing Scaling from “100 ppm” to “250 ppm”**

Figure 22: Example of Changing Scaling from “100 ppm” to “250 ppm” shows an example of changing the analog output scaling. The “CFG” switch is enabled, the “100 ppm” switch is turned OFF, the “250 ppm” switch is turned ON, and the LED to the left of the “250 ppm” switch is illuminated.

While in configuration mode and changing the analog output scaling, all switches that are selected and turned ON will have their associated LED illuminated. If no switches are selected, no LEDs will be illuminated. A valid configuration requires that only one switch can be selected and one LED illuminated.

### 10.3.5 Exiting Configuration Mode

When configuration is complete and valid, with only one switch set for oil type and one for analog output scaling, and the “TEST” switch is turned OFF, the switch for configuration labeled “CFG” is moved from the left to the right using the provided golf tee. When this is done successfully and after approximately a 30 second delay, the LEDs will again turn on in sequence except going from bottom to top, right to left. The LEDs will be illuminated starting with the “100,000 | 5,000” at the bottom of the analog output scaling, going up through the scaling LEDs, through “OIL | GAS”, and through the oil type LEDs ending with “MINERAL” being the last to illuminate. During the delay before the LED sequencing, the GSAO-1 configuration is stored in non-volatile memory and any configuration changes to the GRIDSCAN 5000 Hydrogen sensor system are communicated and saved in its non-volatile memory.

The system will then display the valid configuration by illuminating the appropriate LED next to oil type and next to analog output scaling. The front panel Blue service LED will then reflect the current status of the GSAO-1 and Hydrogen sensor system. If there are no errors, the Blue LED will be turned OFF. The analog output, through the configured scaling will then reflect the Hydrogen concentration reported by the sensor.

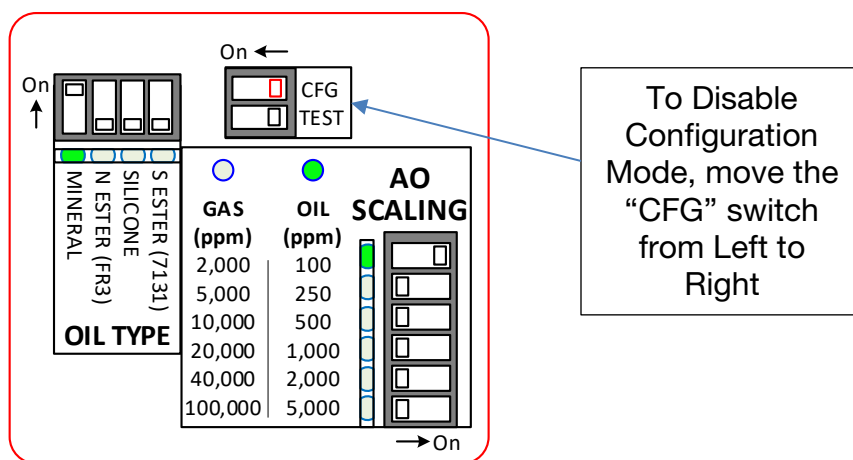

**Figure 23: Disabling Configuration Mode**

If the GSAO-1 configuration mode is disabled by turning the “CFG” switch OFF and there is an error with oil type or analog scaling, the last valid oil type and analog output scaling setting stored in memory will be used. If no switch in either the oil type or analog scaling blocks are selected, all of the oil type LEDs or all of the analog output scaling LED’s will flash once /second. If more than one oil type or analog output scaling switch are selected, the LEDs associated with the selected switches will flash once / second. Additionally, to indicate the invalid configuration, the Blue service LED will blink 6 times every 12 seconds.

If the GSAO-1 configuration mode is disabled by turning the “CFG” switch OFF and there are NO errors with oil type, the new configuration is stored in the GSAO-1 and is implemented in the Hydrogen sensor. The new configuration is then indicated by the oil type LED.

## 11 Re-Sealing the GSAO-1

After the GSAO-1 unit has been installed, wired, and configured, the checklist below should be followed to ensure that the module will seal properly and operate without issue.

- ✓ Make sure that no LEDs are flashing. Flashing indicates that there is an issue that should be resolved before leaving the installation site.
- ✓ Make sure that the Blue service LED is not illuminated by resolving the service condition(s).
- ✓ Make sure that the wires are properly dressed and secured with cable ties.
- ✓ Before closing the cover, install the provided desiccant package into the unit and the wooden golf tee for future re-configurations.
- ✓ Carefully close the cover ensuring that none of the wires are pinched between the cover and enclosure.
- ✓ Securely tighten the two captive cover screws to compress the cover into the gasket. (1.13 N\*m / 10 in\*lb)
- ✓ Re-secure the latch by rotating it towards the enclosure and depress it until it clicks.

## 12 Troubleshooting

The following is a guide is to be used to help resolve some of the common issues.

**Table 7: GSAO-1 Troubleshooting Guide**

Condition	Possible Cause	Remedy
Lab DGA says there is 0-50 ppm of Hydrogen, but the analog output is 4 mA (0 ppm)	The sensor has not operated long enough to get an accurate reading	Wait 16 hours
	The analog output scaling is too high	Set the analog output scaling to 100 ppm
I set a new analog output scaling, but it reverts to the old setting	More than one scaling switch was set when in configuration mode	Re-enter configuration mode, make sure that the appropriate scaling level is selected and indicated by the LED and then exit configuration mode
	No scaling switch was set when in configuration mode	
	The analog scaling switch is broken	Select the next higher or lower scaling level
During configuration, the switch settings and LEDs don't match	The analog scaling switch is broken and stuck OFF	Select the next higher or lower scaling level
	The analog scaling switch is broken and stuck ON	Contact Distributor
	Broken LED	Select the next higher or lower scaling level
The Hydrogen Reported is not consistent with lab DGA	The wrong oil type may be configured	Enter configuration mode, select proper oil type
	Possible Oil Sampling Error	Resample the oil for lab DGA
Unit is not working properly	Loose wires	Check and re-secure wires into the connectors
	Impedance mismatch on analog output	Confirm 250 Ohms or less
The Window is fogged from the inside	The desiccant pack is saturated with moisture	Replace the Desiccant pack

### 13 Unique LED Patterns

The following is a guide is to be used to help resolve some of the common problems.

**Table 8: GSAO-1 Unique LED Patterns Guide**

Condition	Possible Cause	Remedy
Blue LED flashing 1x every 12 seconds	GRIDSCAN 5000 Error	Power cycle GSAO-1 and sensor. If problem persists, replace GRIDSCAN 5000
Blue LED flashing 2x every 12 seconds	GSAO-1 Memory Save Error	Reconfigure oil type and analog output scaling <i>If persistent, replace GSAO-1</i>
Blue LED flashing 3x every 12 seconds	Serial Number of connected GRIDSCAN 5000 is not the same as in memory	Put the GSAO-1 into Configuration Mode and then take it out of configuration mode to save new sensor serial number.
Blue LED flashing 4x every 12 seconds	Memory information is not valid	Reconfigure the GSAO-1 by selecting only one oil type and one scaling factor
Blue LED flashing 5x every 12 seconds	RAM Information is not valid	Power cycle the GSAO-1
Blue LED flashing 6x every 12 seconds	Switch settings are not valid	Reconfigure oil type and analog output scaling. Confirm only one switch set for each

### 14 Analog Output Range Information

The following table is for reference only and is provided to show examples of scaling of the analog output for an oil calibrated sensor.

DIP Switch Setting	Analog Output Range (PPM)	Hydrogen Value at 4mA (PPM)	Hydrogen Value at 20mA (PPM)	Approximate Hydrogen Value at 24mA (PPM)	Analog Output While in TEST Mode (mA)
100	0-100	0	100	140	12
250	0-250	0	250	350	12
500	0-500	0	500	700	12
1000	0-1000	0	1000	1400	12
2000	0-2000	0	2000	2800	12
5000	0-5000	0	5000	7000*	12

\* Note that the Service LED will be illuminated for reported concentrations above 5000 ppm in Oil.

**Table 9: GSAO-1 Analog Output Range Information**

# GSAO-1 Analog Output Module Installation and Configuration *Quick-Start* Guide

## START HERE



### 4 Mounting GSAO-1 Using 4x #10 Stainless Steel Screws and star washers (Included) DO NOT OVER TIGHTEN

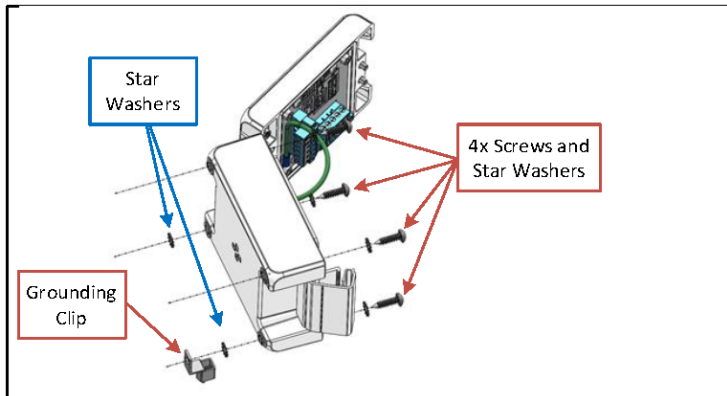

Turn Page Over to Continue

### 1 What's in the Box?

- |  |                           |
|--|---------------------------|
| >1 GSAO-1 Analog Output Module   | >1 Flat Blade Screwdriver |
| >1 pk containing 4 ea #10 Stainless Steel Sheet Metal Screws and 6 ea Star Washers | >1 3 mm HexL-Key          |
| >1 External Grounding Kit  | >1 Desiccant Pack         |
| >2 Wiring Connectors that mate to the PCBA   | >1 Wooden Golf Tee        |
| >1 pk containing 1 ea screw and washer for internal cable shield grounding         | >7 Cable Ties             |
|  | >1 Quick-Start Guide      |



### 2 Tools Required

- > Portable Drill - For Drilling Pilot Holes and Driving Mounting Screws
- > 3mm (0.125") Drill Bit - For Drilling Pilot Holes into Metal
- > Bit Extender - For Driving Mounting Screws
- > #2 Phillips Drive Bit - For Driving Mounting Screws with Drill
- > #2 Phillips Screw Driver - For Driving Screw for Cable Shield Ground
- > Adjustable Wrench - For Tightening Gland Fittings
- > Wire Stripper - For Preparing Wires for Connection
- > Wire Cutters - For Cutting Wires to Length and Trimming Cable Ties
- > Marker or Pencil - To Mark Hole Locations and Wire Cut Lengths



### 3 1:1 Plot for Mounting the GSAO-1

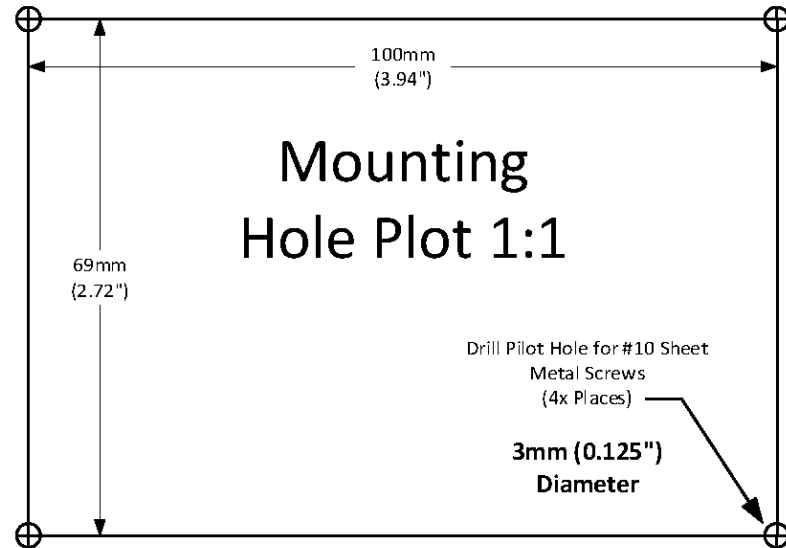

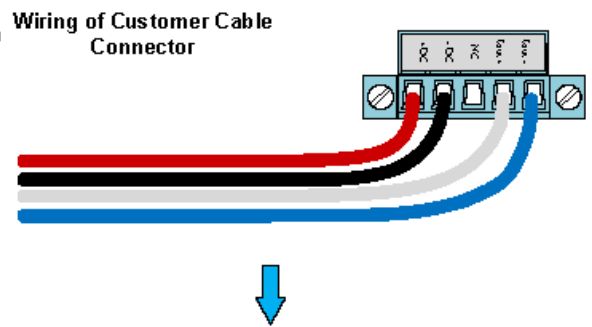
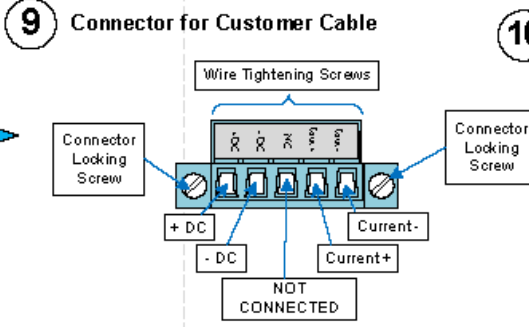
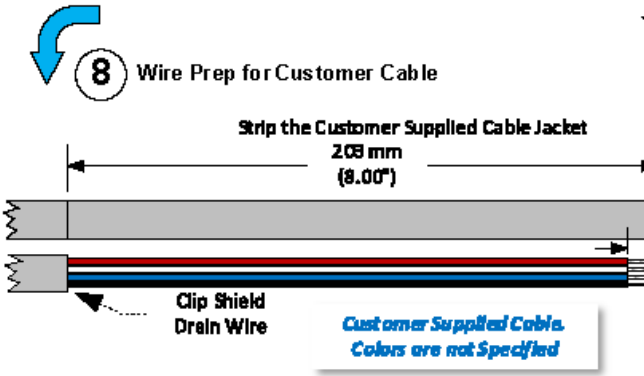
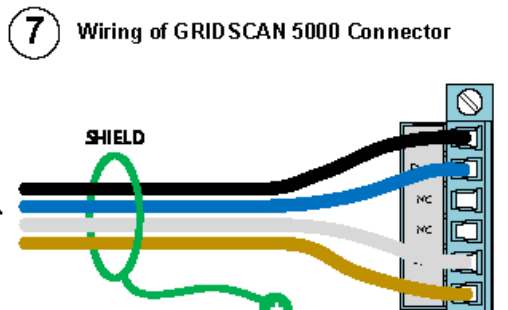
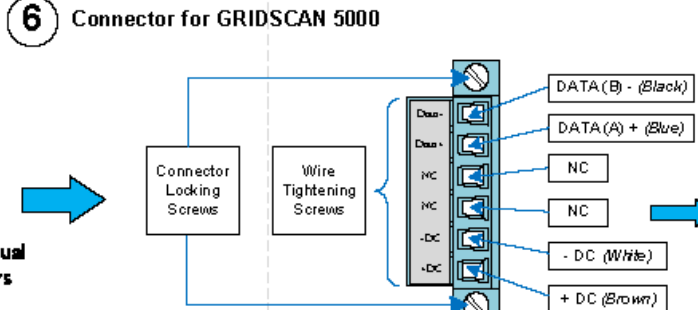
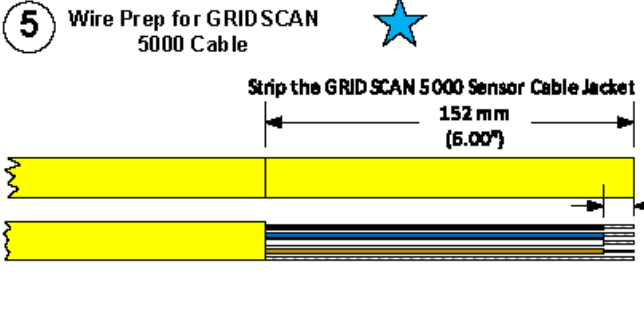

### 12 Configuration

A) Turn "CFG" Switch ON  
*Lights will Dance*

B) Set only ONE Oil Type Switch (Off Oil Calibrated Sensor)  
*On is UP Only One Switch and LED*

C) Set only ONE Scaling Switch  
*On is RIGHT Only One Switch and LED*

D) Turn "CFG" Switch OFF for Normal Operation  
*Lights will Dance*

OIL TYPE	GAS (ppm)	OIL (ppm)	SCALING
MINERAL	2,000	100	
N ESTER (FR3)	5,000	250	
SILICONE	10,000	500	
5 ESTER (7131)	20,000	1,000	
	40,000	2,000	
	100,000	5,000	

NOTE: Only ONE Oil Type and only ONE Scaling Switch Can be Set to be Valid

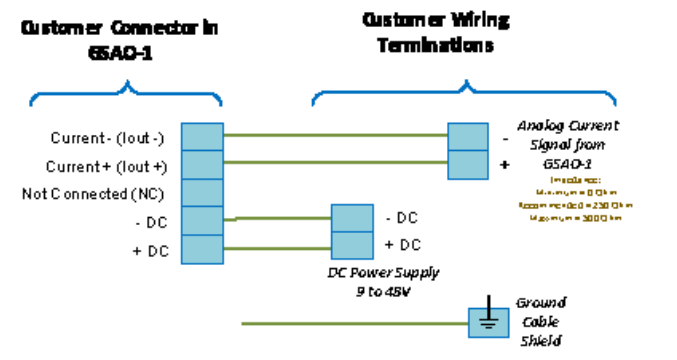
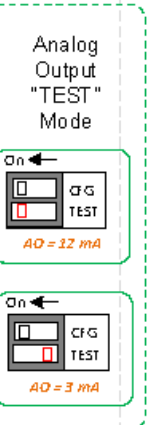

### 13 Technical Support

help@h2scan.com

