

**H2scan**<sup>®</sup>  
Advanced Hydrogen Sensing



OPERATING MANUAL

# HYAO-1

## Analog Output Module

27215 Turnberry Lane, Unit A  
Valencia, CA 91355, USA  
Tel: (661) 775-9575  
E-mail: [hello@h2scan.com](mailto:hello@h2scan.com)  
Website: [www.h2scan.com](http://www.h2scan.com)

## IMPORTANT NOTICES



Read and understand this operating manual before installing or using the unit.  
If this equipment is used in a manner not specified by H2scan, the protection provided by this equipment may be impaired.

**LIMITATION OF LIABILITY** - seller shall under no circumstances be liable for any incidental, consequential, special, punitive, or other damages, including, but not limited to, loss of business or profit, promotional or manufacturing expenses, injury to reputation, or loss of customer, based on any alleged negligence, breach of warranty, strict liability, breach of contract, or any other legal theory arising out of the use, misuse, purchase, sale or possession of its goods or its performance of this contract to the extent that such liability extends seller's obligations beyond the price paid by buyer to seller for the item on which such claim is based. Seller advises buyer to perform acceptable tests on all hardware prior to deployment and to perform maintenance as described in the seller's instruction guide. Under no circumstances shall the equipment provided hereunder be used in a manner where it is the sole protective system for facilities, equipment, and personnel safety; the equipment is intended for use in conjunction with other appropriate protective systems.

## LIMITED WARRANTY

**H2scan Limited Warranty:** Each HYAO-1 analog output module ("Product") will conform, as to all substantial operational features, to the Product specifications set forth in this Manual and will be free of defects which substantially affect such Product's performance for thirty-six (36) months from the ship date for such Product.

**Must Provide Notice of Defect:** If you have a Product that you believe is defective, you must notify H2scan in writing, within the warranty period of your claim regarding any such defect.

**Return Product to H2scan for Repair, Replacement or Credit:** The customer is responsible for shipping and handling costs. If the Product is found defective by H2scan, H2scan's sole obligation under this warranty is to either (i) repair the Product, (ii) replace the Product, or (iii) issue a credit for the purchase price for such Product, the remedy to be determined by H2scan on a case-by-case basis. A valid RMA number must be assigned by H2scan and clearly marked on the package when the unit is returned.

**Voided Warranty:** H2scan's 3-year Limited Warranty is void for any of the following:

- Unauthorized repair work performed at the customer's location or conducted by anyone other than H2scan's factory trained technicians.
- Equipment or parts that have been tampered with, misused, neglected, mishandled, improperly adjusted, or modified in any way without the written consent of H2scan.
- Equipment or parts that have been damaged due to shipping, misuse, accidents, mishandling, neglect, or problems with electrical power sources.
- Repair work performed during the warranty period does not prolong the warranty period past the original period.
- System operation in incorrect or inappropriate environments.
- Usage that is not in accordance with system guidelines or an operator's failure to follow manual instructions.

**LIMITATION OF WARRANTY:** THE ABOVE IS A LIMITED WARRANTY AS IT IS THE ONLY WARRANTY MADE BY H2SCAN. H2SCAN MAKES NO OTHER WARRANTY EXPRESS OR IMPLIED AND EXPRESSLY EXCLUDES ALL WARRANTIES OF MERCHANTABILITY AND FITNESS FOR A PARTICULAR PURPOSE. YOUR SOLE REMEDY HEREUNDER IS REPAIR OR REPLACEMENT OF THE PRODUCT OR A CREDIT FOR THE PURCHASE PRICE FOR SUCH PRODUCT, THE PARTICULAR REMEDY TO BE DETERMINED BY H2SCAN ON A CASE-BY-CASE BASIS. H2SCAN SHALL HAVE NO LIABILITY WITH RESPECT TO ITS OBLIGATIONS UNDER THIS AGREEMENT FOR CONSEQUENTIAL, EXEMPLARY, OR INCIDENTAL DAMAGES EVEN IF IT HAS BEEN ADVISED OF THE POSSIBILITY OF SUCH DAMAGES. THE STATED EXPRESS WARRANTY IS IN LIEU OF ALL LIABILITIES OR OBLIGATIONS OF H2SCAN FOR DAMAGES ARISING OUT OF OR IN CONNECTION WITH THE DELIVERY, USE OR PERFORMANCE OF THE PRODUCTS.

## CONTENTS

<b>1</b>	<b>INTRODUCTION .....</b>	<b>4</b>
<b>2</b>	<b>FEATURES.....</b>	<b>4</b>
2.1	OUT OF THE BOX.....	4
2.2	TOOLS FOR MOUNTING AND COMMISSIONING .....	4
2.3	MECHANICAL .....	5
2.4	ENCLOSURE SEALING .....	5
2.5	ELECTRICAL FEATURES .....	5
<b>3</b>	<b>SPECIFICATIONS.....</b>	<b>6</b>
3.1	CERTIFICATIONS.....	7
<b>4</b>	<b>PRODUCT OVERVIEW .....</b>	<b>8</b>
4.1	FRONT VIEW FEATURES:.....	8
4.2	OPEN VIEW FEATURES: .....	8
<b>5</b>	<b>LABELING.....</b>	<b>9</b>
<b>6</b>	<b>ENCLOSURE ACCESS .....</b>	<b>9</b>
<b>7</b>	<b>MOUNTING .....</b>	<b>10</b>
<b>8</b>	<b>ELECTRICAL INTERFACE .....</b>	<b>12</b>
8.1	GLAND FITTINGS .....	12
8.2	CABLES.....	12
8.3	WIRING CONNECTIONS .....	13
8.3.1	Earth Grounding the HYAO-1 Module .....	13
8.3.2	HY-OPTIMA 5030 Series Hydrogen Sensor Wiring Connections .....	14
8.3.3	Customer Wiring Connections .....	15
8.3.4	Customer Wiring Terminations (Not at HYAO-1) .....	17
8.3.5	Wire Dressing.....	17
8.4	POWER SUPPLY .....	18
<b>9</b>	<b>OPERATION.....</b>	<b>18</b>
9.1	STARTUP .....	18
9.2	FRONT PANEL LEDES.....	19
9.3	ANALOG OUTPUT .....	19
9.4	SERVICE CONDITIONS .....	19
<b>10</b>	<b>RE-SEALING THE HYAO-1.....</b>	<b>20</b>
<b>11</b>	<b>TROUBLESHOOTING.....</b>	<b>21</b>
<b>12</b>	<b>UNIQUE LED PATTERNS.....</b>	<b>21</b>
<b>13</b>	<b>ANALOG OUTPUT RANGE INFORMATION .....</b>	<b>22</b>

## 1 Introduction

The HYAO-1 Analog Output Module is designed to provide an accurate, reliable, and robust 4-20mA analog output for the HY-OPTIMA 5030 Series Hydrogen Sensor system. The robust electronics and physical designs are appropriate for use in for process and safety applications, and over a wide range of environmental conditions.

The HYAO-1 is powered with nominal 9 to 48 VDC, which is passed through to the HY-OPTIMA 5030 Series Hydrogen Sensor System. Only two cables are required; one to connect the HYAO-1 Module to the Hy-Optima 5030 Series Hydrogen Sensor with power and communications, and one from the customer supplying DC power and taking the analog signal out to the customer's data system.

The HYAO-1 automatically detects which HY-OPTIMA 5030 Series sensor model is connected and automatically scales the 4-20 mA outputs appropriately

The HYAO-1 has easily visible status LEDs to indicate that the unit is powered and to indicate any service conditions.

The small and compact size allows for easy installation almost anywhere, and the enclosure allows for use of the supplied cable gland fittings or conduit fittings for a secure and rugged installation.

This document has been updated for use with HYAO-1 firmware revision **hyao1r006**.

## 2 Features

### 2.1 Out of the Box

Every HYAO-1 Analog Output Module is shipped with the following:

- One HYAO-1 Analog Output Module
- One package containing 4 each #10 stainless steel sheet metal screws and 6 each star washers
- One External Grounding Kit
- Two Wiring Connectors that mate to the printed circuit board assembly
- One Package containing 1 screw and star washer for internal cable shield grounding
- One Flat Blade Screwdriver for making electrical wiring connections
- One Desiccant Package for moisture removal inside of the HYAO-1 Module
- One 3mm Hex L-Key for opening and securing the enclosure cover
- Seven Cable Ties for dressing wires
- One Quick-Start Guide Including:
  - ✓ Package Content List
  - ✓ Tools Required for installation
  - ✓ 1:1 Template for easily identifying mounting hole locations
  - ✓ Mounting and Grounding Instructions
  - ✓ Wire Stripping Length Guide and Ruler
  - ✓ Wiring Instructions
  - ✓ Configuration Instructions
  - ✓ Help and Contact Information

### 2.2 Tools for Mounting and Commissioning

For mounting the HYAO-1 to panels, the following tools are required:

- Electrical Drill with Bit Extender – to drill pilot holes and hold the driver bit
- 3 mm (1/8”) Hardened Drill Bit – for making pilot holes
- #2 Phillips Head Drive Bit – to drive the mounting screws with drill
- #2 Phillips Head Screwdriver – to secure cable shield grounding
- Adjustable Wrench – to tighten the cable gland fittings
- Wire Cutters – to trim wires to length and trim cable ties
- Wire Strippers – to properly strip wires without damage to the conductors
- Marker or Pencil – to mark holes to drill and wiring stripping

### 2.3 Mechanical

The HYAO-1 Analog Output Module has a rugged waterproof and dustproof mechanical assembly design for various transformer applications. The enclosure is easily mounted using the four mounting holes and the included #10 18-8 stainless steel screws. The HYAO-1 is rated IP68 and can be used in most environments.

Overall dimensions are shown below.

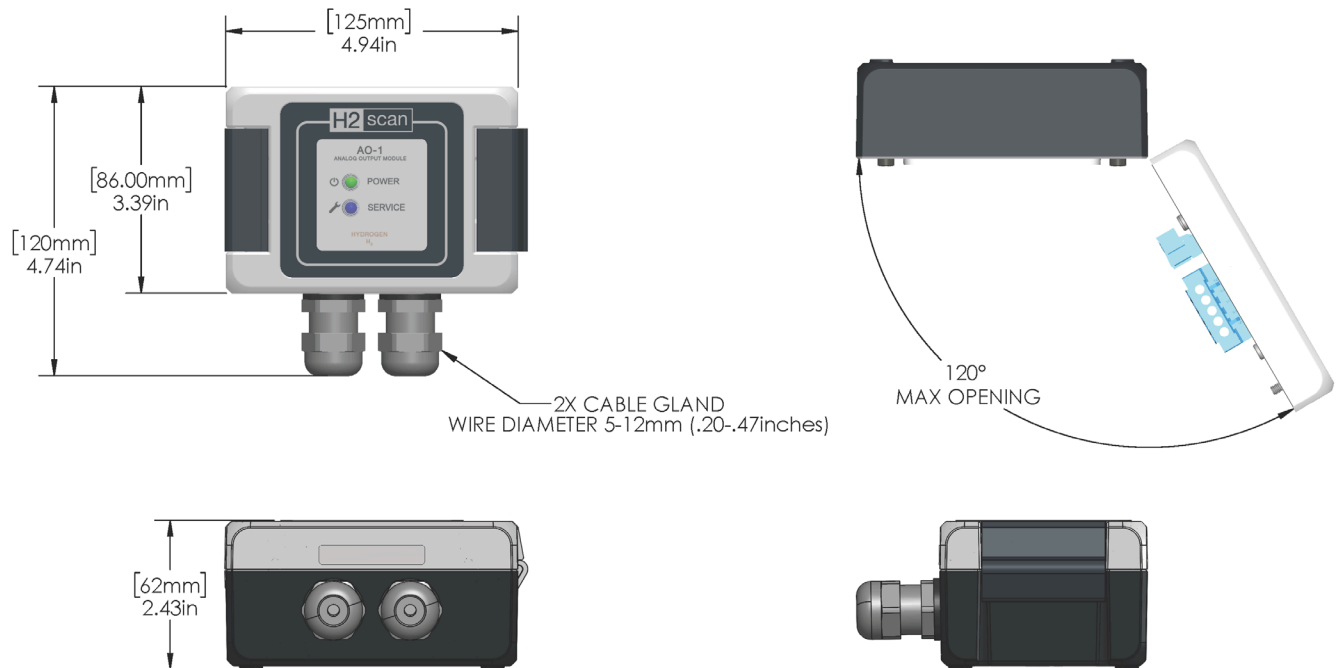

**Figure 1: HYAO-1 Dimensions**

### 2.4 Enclosure Sealing

There are three main sealing components within the HYAO-1 Analog Output Module system; the cover gasket seal, the window seal, and the cable gland seal.

The gasket sealed precision die-cast enclosure of the HYAO-1 Analog Output Module has a sealed chemically strengthened glass window and is provided with cable gland fittings. The combination provides a system that is rated for IP68 for water and dust ingress. The cable gland fittings can be replaced by the customer with 1/2" conduit gland fittings, but this may impact the ingress protection rating. H2scan offers adaptors for metric M20. Only properly installed IP66 or better rated conduit gland fittings are supported by H2scan. Failure to use proper gland fitting solutions may void the product warranty. Use of conduit fittings rated less than IP68 will decrease the rating of the system to the rating of the conduit fittings used.

### 2.5 Electrical Features

A cable is required for connecting the HYAO-1 Analog Output Module to the HY-OPTIMA 5030 Series Hydrogen Sensor. The required cable has a single 4-pin M12 connector for connection at the HY-OPTIMA 5030 Series Hydrogen sensor for power and communications. This connector and cable should be rated for IP66 or better to

match the sensor installation conditions. The other end of the cable has individual wire leads for connection to the HYAO-1 module. (see wiring instructions section [8.3.2](#))

Additionally, the customer must supply DC power to the HYAO-1 module and take the analog signal out to their data system. This cable should be a four-conductor cable with wire size up to 4 mm (12 AWG) for the following:

- 2-wire DC power input of 9 to 48 volts, 13 watts (24 VDC or 48 VDC Power Supply is recommended)
- 2-wire current loop for the 4-20 mA output. Powered by HYAO-1 with the following impedance requirements:
  - 0 Ohm minimum load.
  - 250 Ohm recommended load.
  - 500 Ohm maximum load.

It is recommended that all cables be shielded with a drain wire grounded at one end.

### 3 Specifications

**Table 1: HYAO-1 Analog Output Specifications**

Parameter	Value			Units
	Minimum	Nominal	Maximum	
Normal Current	4		20	mA
High Current	20		24	mA
High Current Service	24			mA
Low Current Service	0		4	mA
Accuracy	±0.04 mA			
Scaling of 4 mA	Equal to 0 ppm of Hydrogen			
Scaling at 20mA	Model Number Auto-Scaled to Equal:			
	<b>Model</b> HY-OPTIMA 5031 HY-OPTIMA 5032 HY-OPTIMA 5033 HY-OPTIMA 5034 HY-OPTIMA 5020	<b>Hydrogen</b> 10% (100,000 ppm) 5% (50,000 ppm) 100% (1,000,000ppm) 100% (1,000,000ppm) 5% (50,000ppm)		
Calibration Interval	No periodic calibration of HYAO-1 is required			

**Table 2: HYAO-1 Operating Conditions**

Parameter	Value			Units
	Minimum	Nominal	Maximum	
<b>Environment – Ambient</b>				
Operating Temperature	-40	25	70	°C
Storage Temperature	-40		85	°C
Ingress Protection	IP68 (IEC 60529) with provided cable gland fittings			
Humidity	0 to 100% RH, condensing			
Altitude	Up to 2000 m (6560 ft)			
<b>Mechanical</b>				
Vibration	3-axis Sinusoidal, Wideband and Random (IEC 60068-2-6 table C.2, IEC 60068-2-64 paragraph A.2, category no. 2, IEC 61373: 2010 Cat 1B section 9)			
Shock	30g, shock duration 18ms (IEC 60068-2-27)			
<b>Electrical</b>				
Voltage Input, Absolute Maximum	8.1	24	52.8*	VDC
Power Consumption			13**	W

\* Do NOT exceed maximum voltage

\*\* Includes power to the HY-OPTIMA 5030 Series Hydrogen Sensor

### 3.1 Certifications

List of standards:

- Capability Damped Oscillatory IEC 61000-4-12
- Conducted RF IEC 61000-4-6: 2009
- Surge IEC 61000-6-5; IEC 61000-4-5: 2006
- Radiated RF IEC 61000-6-5; IEC 61000-4-3: 2010
- Electrostatic Discharge IEEE C37.90.3: IEC 61000-4-2: 2009
- Dielectric Strength IEC 60255-2: 2000; IEEE C37.90-2005
- Impulse IEC 60255-5: 2000
- Fast Transient; Burst IEC 60255-22-4: 2008; IEC 61000-4-4: 2011
- Conducted Emissions EN 55011 Class A
- Radiated Emissions EN 55011 Class A
- Magnetic Field IEC 61000-4-8: 2010
- Voltage Dips and Interrupts IEC 61000-4-11: 2004
- Ingress Protection IEC 60529: 1986/AMD2:2013/Cor1:2019
- Humidity and Corrosion Resistance C5M Marine Rated; IEC 60068-2-11, DIN EN ISO 12944
- Vibration – Sinusoidal IEC 60068-2-6 Table C2; IEC 60068-2-64 Par A.2
- Vibration – Shock and Bump IEC 60068-2-27; 30g @ 18ms
- Electrical Safety EN 61010-1:2010 (including 60255-2 Dielectric Strength)

Directives

- Restriction of Hazardous Substances RoHS 3 Directive 2015/863 plus Category 11
- REACH EC No.197/2006
- Dodd- Frank Conflict Mineral Compliance Dodd – Frank Section 1502

## 4 Product Overview

### 4.1 Front View Features:

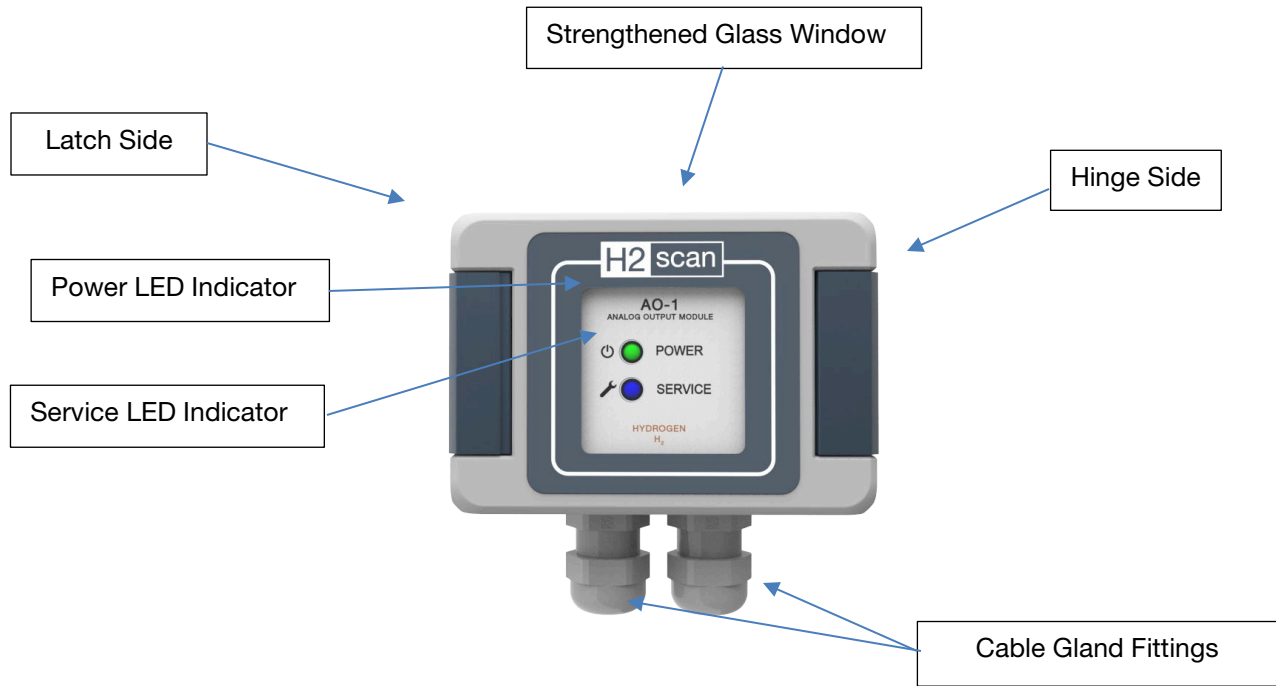

**Figure 2: HYAO-1 Front View Features**

### 4.2 Open View Features:

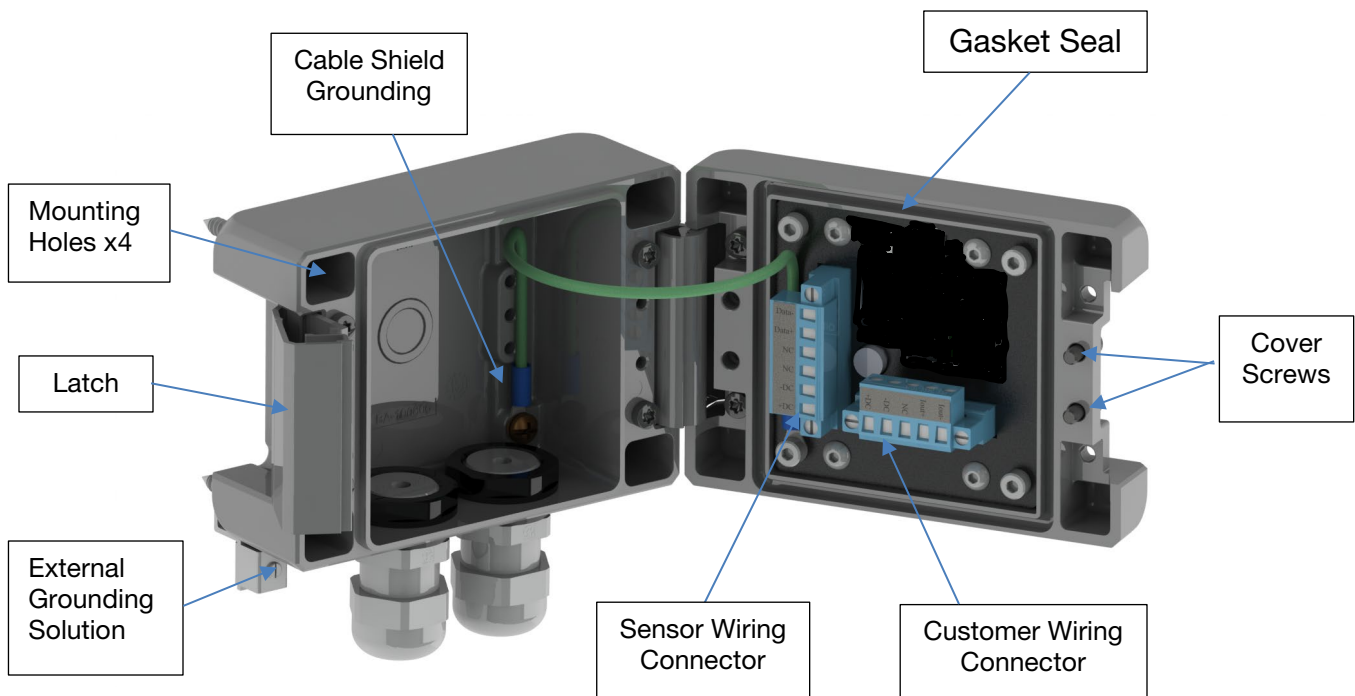

**Figure 3: HYAO-1 Open View Features**

## 5 Labeling

The product label is a permanent externally mounted label containing the manufacturer or distributor name, model number, the manufacturer's part number, a serial number, the date of manufacture, and compliance marking for CE and FCC.



**Figure 4: HYAO-1 Product Label**

## 6 Enclosure Access

When looking at the front panel of the HYAO-1 unit, the latch is located on the left side of the enclosure. From the front, the latch will release and will swing from the front to the left. This exposes the cover screws that compress the cover to the base. These screws are held captive in the cover and will not fall out. Using the supplied 3mm hex L-Key, loosen the cover screws until they are no longer locking the cover to the base. The cover will then easily swing to the right.

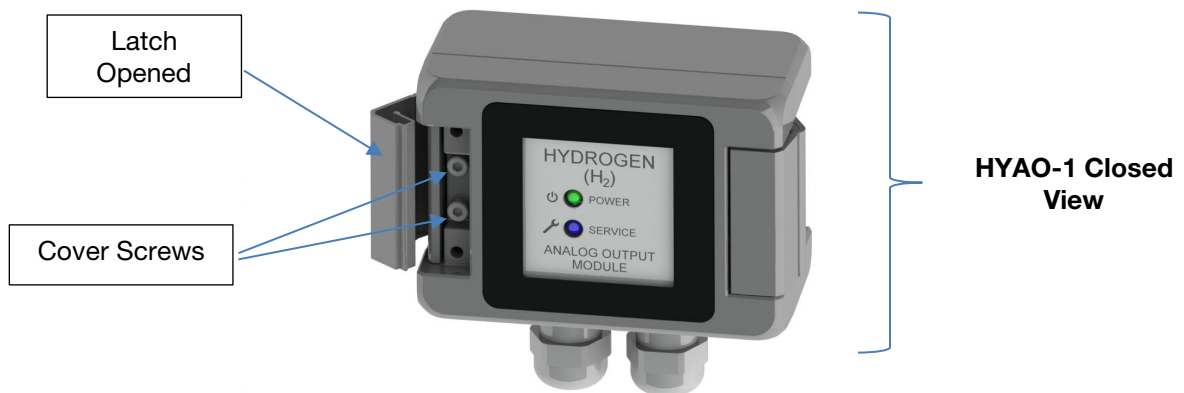

**Figure 5: HYAO-1 Closed View for Access**

**HYAO-1 Opened View**



**Figure 6: HYAO-1 Open View for Access**

To close the cover, reverse the steps making sure to tightly secure the cover screws. This should be to approximately 1.13 N\*m (10 in\*lb). Failure to tighten the cover screws can compromise the sealing of the HYAO-1 unit and may compromise the IP rating of the system.

**7 Mounting**

The HYAO-1 can be easily mounted to panels and plates. Included with every unit in the Quick-Start Guide is a 1:1 template for easily locating the appropriate mounting hole locations. The included stainless-steel machine screws require that pilot holes be drilled using a 3mm (1/8”) drill bit. It is recommended that pilot holes be marked and drilled prior to mounting the HYAO-1 module to generate the most robust and secure mounting.

Install the unit with the provided #10 stainless steel screws to approximately 6.3 N\*m (56 in\*lb).

For external grounding of the HYAO-1 module, the grounding kit provided generates metal-to-metal contact through the mounting screws. The grounding clip is installed when mounting the HYAO-1 unit in conjunction with the provided star washers. Specifically for the mounting of the grounding clip, a star washer should be installed on the screw that is inserted into the mounting hole AND an additional star washer should be installed between the enclosure base and the grounding clip. Use the last remaining star washer on the adjacent corner to level the mounted unit.

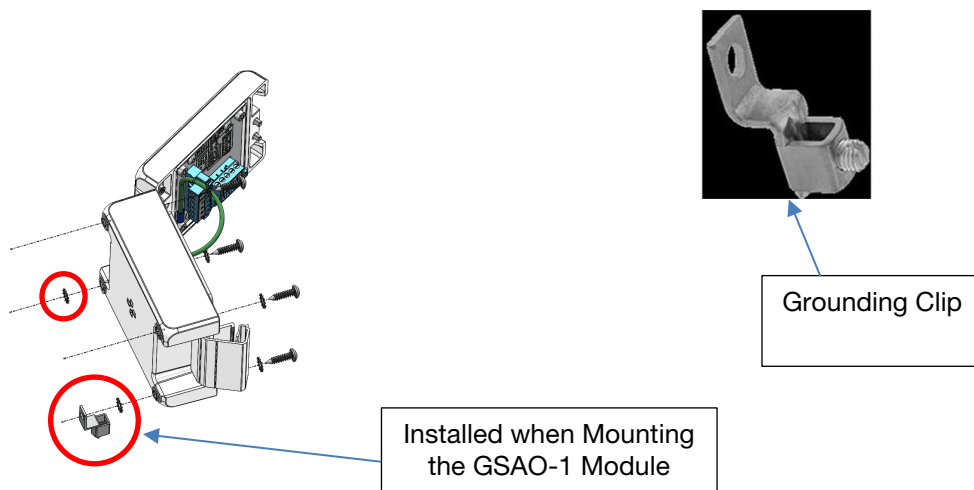

**Figure 7: HYAO-1 External Grounding Solution**

Alternatively, the HYAO-1 module can be mounted using DIN rail, Unistrut, or wedge anchors into concrete or masonry.

The customer is responsible for properly grounding the HYAO-1 module.

It is recommended that the HYAO-1 be mounted within  $\pm 10^\circ$  of level.

## 8 Electrical Interface

All electrical connections to the HYAO-1 Analog Output Module are supplied through two multi-conductor cables. One cable supplies power to, and exchanges data with, the HY-OPTIMA 5030 Series Hydrogen Sensor. The other cable is supplied by the end user to provide DC power to the HYAO-1 and to take the analog output current loop to their control system.

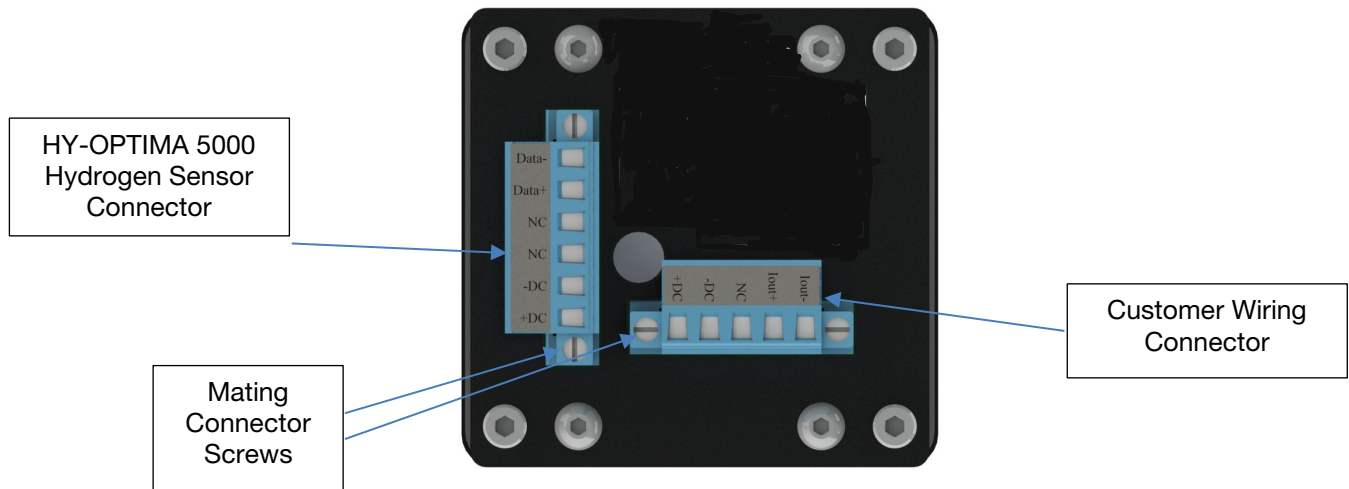

**Figure 8: HYAO-1 Electrical Connectors**

Each connector is comprised of two pieces; one that is mounted to the printed circuit board assembly (PCBA), and a mating connector that is secured to the PCBA connector with two captive screws. Due to keying of the mating connectors, they can only be plugged into the PCBA portion of the connector one way. Each of the mating connectors is clearly labeled with the wiring locations on the mating connector.

### 8.1 Gland Fittings

The HYAO-1 Analog Output Module is supplied with two IP68 rated cable gland fittings that accommodate 5 mm to 12 mm (0.20" to 0.47") Outside Diameter jacketed cables.

If it is desired to utilize conduit to route cables to and from the HYAO-1, the cable gland fittings can be replaced by standard 1/2" conduit gland fittings without modification to the enclosure. The IP rating of the HYAO-1 is dependent upon the rating and construction of the conduit gland fittings. It is recommended that only IP66 or better rated conduit gland fittings be used. Use of lower rated fittings can result in damage to the HYAO-1 unit and can void the warranty.

Do not install more than one cable per cable gland fitting. Installing more than one cable per gland fitting will compromise the IP rating of the fitting and HYAO-1 module.

If the cable gland fittings are replaced with conduit gland fittings, the IP rating is considered to be IP 66 or less regardless of conduit gland rating. If conduit gland fittings are used, the HYAO-1 should not be mounted where it will be submerged. Doing so voids the warranty.

Modification of the HYAO-1 enclosure to increase the size of the gland fitting ports is not recommended. It can compromise the IP rating of the system and can void the warranty.

### 8.2 Cables

The cable supplied for customer connection should be rated for the environmental conditions it will be used in. A suitably rated cable assembly is required for most field applications.

Cable recommendations are:

- 4 Conductor, 1 to 4 mm (18 to 12 AWG) wire
- Shielded cable with drain wire is recommended
- Outdoor, waterproof, and UV rated jacket

The customer cable shield drain wire should only be grounded at the power supply end and **NOT** in the HYAO-1 Module.

An earth ground conductor should NOT be added to the power and signal cable brought to the HYAO-1 Analog Output Module. Induced currents can affect the operation of the HYAO-1 Module and can cause interference on the analog signal.

The cable used to connect to the HY-OPTIMA 5030 Series Hydrogen sensor is an orderable option available in various lengths. If the cable is not ordered from H2scan, it should be rated for the environmental conditions it will be used in. A suitably rated cable assembly is required for most field applications.

If the cable is not sourced from H2scan, below are the cable recommendations:

- 4-pin M12 Female molded connector
- IP68 rated connector (or applicable IP rating)
- 4 conductor 1mm (18 AWG) wire
- Shielded cable with drain wire is recommended
- Outdoor, waterproof, and UV rated jacket

For cables not ordered from H2scan with the HYAO-1 or HY-OPTIMA 5030 Series Hydrogen Sensor system, the key (notch) location and pin numbers are shown below.

**Table 3: HY-OPTIMA 5030 Series Hydrogen Sensor Pin Out**

Pin	Signal Name	Wire Color
1	DC power	Brown
2	DC ground	White
3	RS485 Data+	Blue
4	RS485 Data-	Black

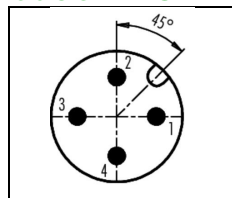

This view is looking at the connector on the HY-OPTIMA 5030 Series Hydrogen Sensor.

The wire colors of the cable listed above are not standard and should not be confused with AC power standards. Do NOT connect the HYAO-1 to AC power. If the HYAO-1 is connected to AC power, permanent damage will occur and will void the warranty.

### 8.3 Wiring Connections

On the mating connector that plugs into the PCBA, there are openings where the stripped wires are inserted and screws, that when tightened, secure the wires into the connector slots. The customer wiring connector has five wiring slots. The HY-OPTIMA 5030 Series Hydrogen sensor connector has six wiring slots.

Wires between 1mm (18 AWG) and 4 mm (12 AWG) can be used. Smaller or larger wires are not recommended or supported.

Bare stripped wire should be used. Tinning is not recommended.

Do NOT unplug or plug wiring connectors when the system is energized.

#### 8.3.1 Earth Grounding the HYAO-1 Module

An earth ground is required to be connected to the case of the HYAO-1 Analog Output Module. It should be added in conjunction with the mounting hardware. (See Section 7)

With the grounding clip securely installed with the HYAO-1 mounting, insert the bare grounding wire into the clip and tighten the set screw.

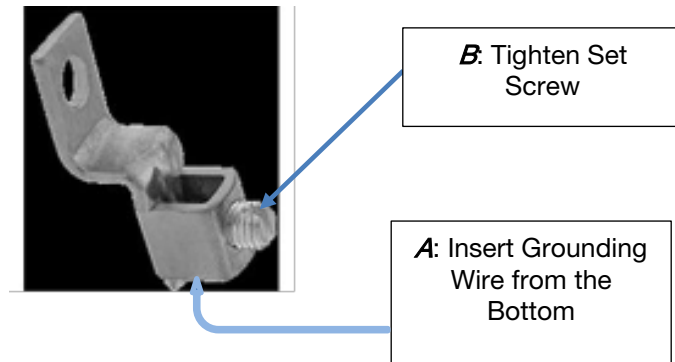

**Figure 9: HYAO-1 External Grounding Connector**

### 8.3.2 HY-OPTIMA 5030 Series Hydrogen Sensor Wiring Connections

After connecting the cable to the HY-OPTIMA 5030 Series sensor, route the cable to the HYAO-1. Secure cable as necessary. Trim the cable to length so that there will be approximately 160 mm (6.5 inches) inside of the HYAO-1 module when assembled.

The standard H2scan multi-conductor cable has four conductors that are 1 mm (18 AWG) and a foil shield with a drain wire.

The cable outer jacket should be stripped to 152 mm (6 inches).

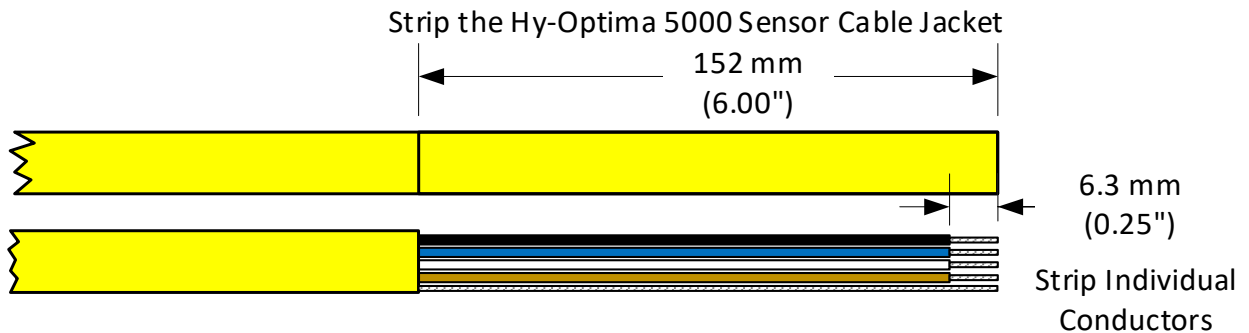
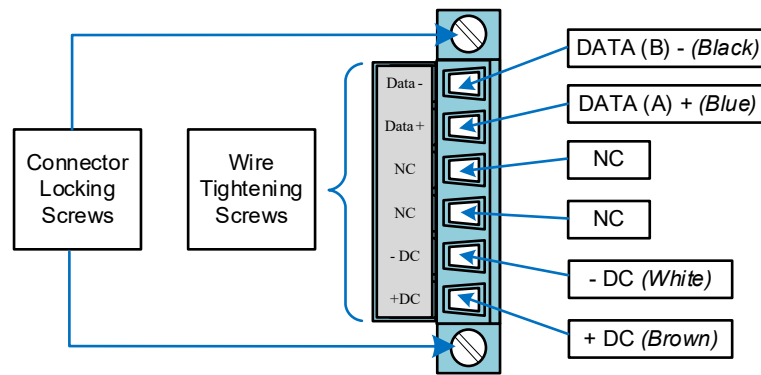

**Figure 10: HY-OPTIMA 5030 Series Cable Stripping**

The ends of the conductors should be stripped 6 mm (¼ inch) from the end. Do not tin or solder the bare metal conductors.

After all wires are stripped, insert the sensor cable through the right gland fitting on the HYAO-1 enclosure closest to the hinge so that 10 mm (½ inch) of the cable jacket is visible inside the enclosure above the gland fitting. Securely tighten the gland fitting to the cable using an adjustable wrench. 0.28 N\*m (2.5 in\*lb)

Insert each wire into the slotted opening on the mating connector in accordance with the label on the connector and as illustrated in the diagram below. Insert only the bare wire and not the insulated portion of the conductor. Secure the wire by tightening the corresponding screw using the provided flat blade screwdriver. 0.5 N\*m (4.42 in\*lb) Do not over tighten or strip the screws. After tightening, gently pull on the wire to ensure it is securely connected. Repeat until all wiring connections have been made.

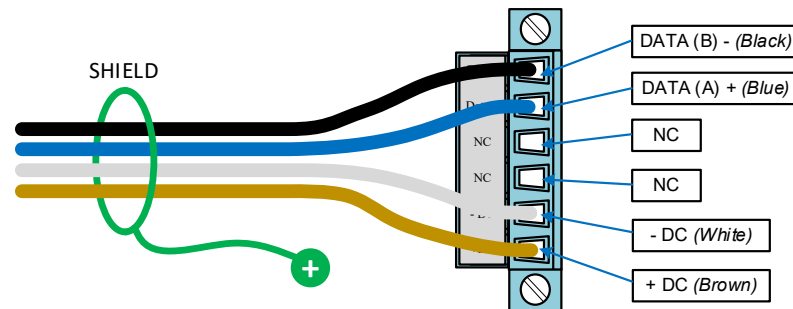

**Figure 11: HY-OPTIMA 5030 Series Hydrogen Sensor Wiring Connector**

View of mating connector as mounted on the circuit board.

In the example shown in *Figure 12: HY-OPTIMA 5000 Hydrogen Sensor Connector with Wires*, the Black wire is connected to DATA (B) -, the Blue wire is connected to DATA (A) +, the White wire is connected to - DC, and the Brown wire is connected to + DC.

Color coding should be confirmed if not using a cable supplied by H2scan.



**Figure 12: HY-OPTIMA 5030 Series Hydrogen Sensor Connector with Wires**

The drain wire for the cable shield should be trimmed to length and secured to one of the multiple locations inside of the enclosure using a provided grounding screw. 1.13 n\*m (10 in\*lbf)

After all wires are securely connected, plug the mating connector into the PCBA and secure with the two connector locking screws. 0.4 N\*m (3.54 in\*lbf) Do not over-tighten.

### 8.3.3 Customer Wiring Connections

The multi-conductor cable used by the customer should have conductors that are between 1 mm and 4 mm (18 AWG and 12 AWG) and should have a minimum of four conductors and a shield with a drain wire. Two conductors should be used for DC power, and two for current loop analog output.

After routing the cable to the HYAO-1 installation, trim any excess cable so that approximately 210 mm (8.5 inches) of cable will be inside the HYAO-1 module.

The cable outer jacket should be stripped to 203 mm (8 inches).

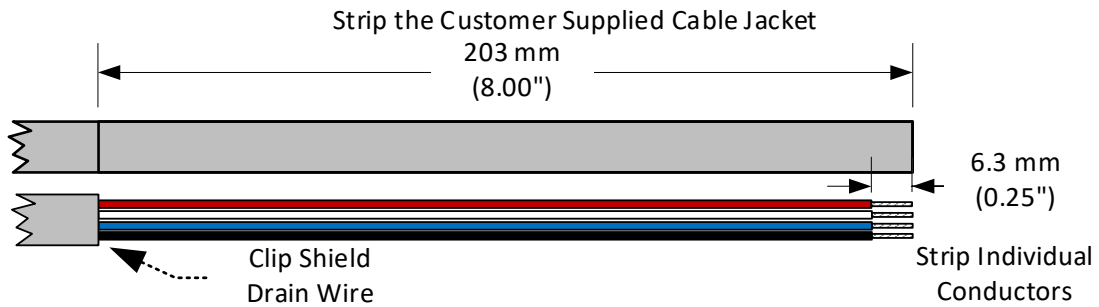
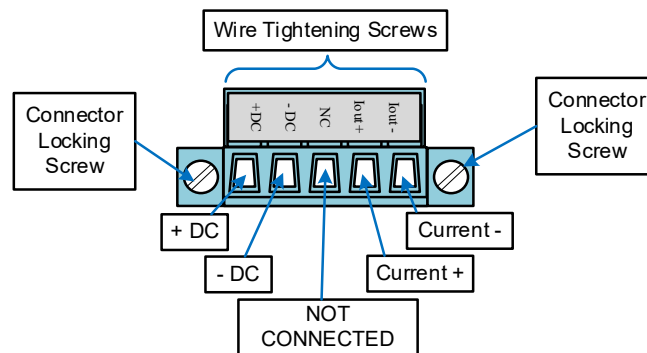

**Figure 13: Customer Cable Stripping**

The ends of the conductors should be stripped 6 mm (¼ inches) from the end. Do not tin or solder the bare metal conductors.

After all wires are stripped, insert the cable through the left gland fitting on the HYAO-1 enclosure so that 10 mm (½ inch) of the cable jacket is visible inside the enclosure above the gland fitting. Securely tighten the gland fitting to the cable using an adjustable wrench. 0.28 N\*m (2.5 in\*lb)

Insert each wire into the slotted opening on the mating connector in accordance with the label on the connector and as illustrated in the diagram below. Insert only the bare wire and not the insulated portion of the conductor. Secure the wire by tightening the corresponding screw using the provided flat blade screwdriver. 0.5 N\*m (4.42 in\*lb) Do not overtighten or strip the screws. After tightening, gently pull on the wire to make sure that it is securely connected. Repeat until all wiring connections have been made.



**Figure 14: HYAO-1 Customer Wiring Connector**

View of the customer mating connector as it is mounted on the circuit board.

In the example shown in *Figure 15: HYAO-1 Customer Connector with Wires*, the Red wire is connected to +DC, the Black wire is connected to – DC, the White wire is connected to Current +, and the Blue wire is connected to Current -.

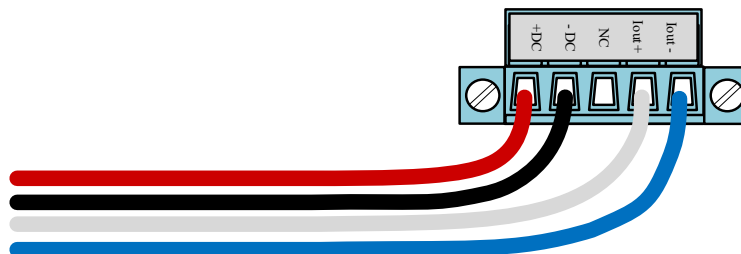
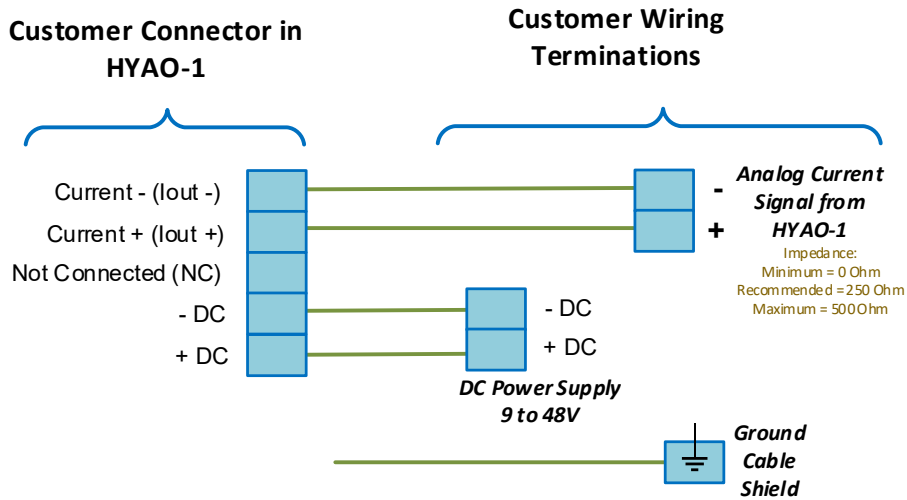

**Figure 15: HYAO-1 Customer Connector with Wires**

After all wires are securely connected, plug the mating connector in the PCBA and secure with the two connector locking screws. 0.4 N\*m (3.54 in\*lb) Do not over-tighten.

**8.3.4 Customer Wiring Terminations (Not at HYAO-1)**

With the customer cable properly terminated in the HYAO-1, the other end must be terminated in the control panel or junction box. Please refer to *Figure 16: Customer Wiring Termination (Not at HYAO-1)* for proper wiring terminations.



**Figure 16: Customer Wiring Termination (Not at HYAO-1)**

The analog signal is to be terminated as illustrated to ensure proper functionality. The impedance of the current loop should ideally be 250 Ohms and no more than 500 Ohms.

The power supply should be connected as illustrated to ensure proper functionality of the HYAO-1.

The cable used should have a shield and drain wire. This drain wire should be grounded at the customer termination end of the cable and NOT inside of the HYAO-1 module.

**8.3.5 Wire Dressing**

With both cables installed, the wires should be dressed so that the DIP switches and internal LEDs can be seen, and so that the cover can be closed without pinching any of the wires. The wires are to be dressed across the hinge side of the enclosure using the supplied cable ties as shown in *Figure 17: HYAO-1 Cable Wire Dressing*. After the cable ties are in place, trim the excess portion of the cable tie with wire clippers.

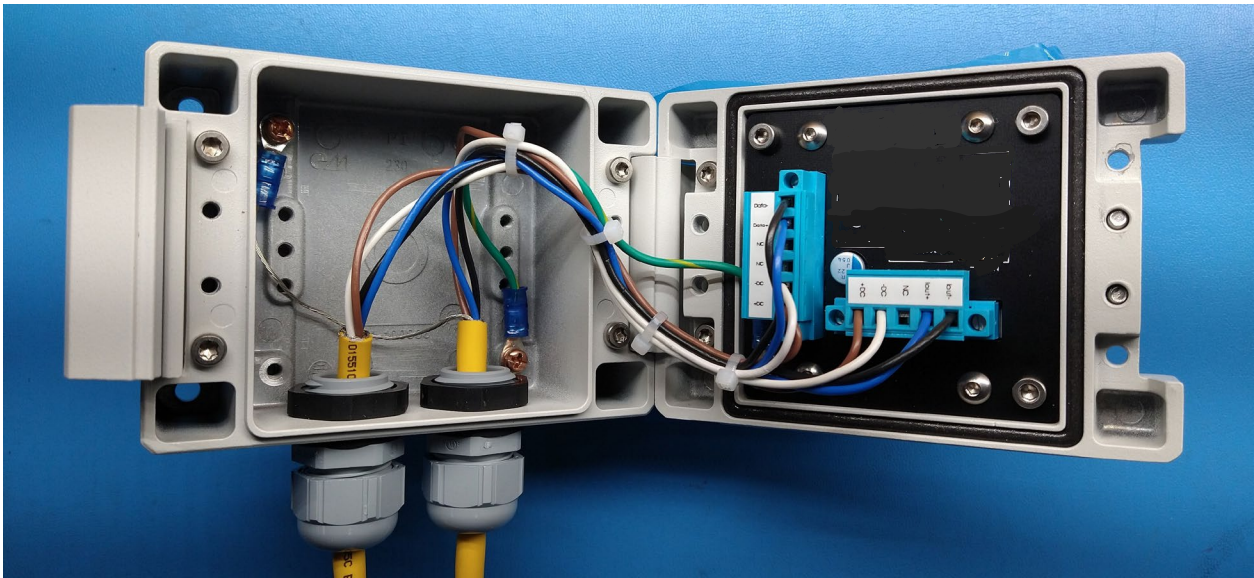

**Figure 17: HYAO-1 Cable Wire Dressing**

## 8.4 Power Supply

It is recommended that the HYAO-1 be powered by an industrial grade fixed output power supply that meets the following specifications:

- DC voltage output
- Output Voltage: 9, 12, 15, 24, 30, 36 or 48 VDC nominal
- Output power: 13 Watts minimum

24 VDC or 48 VDC Power Supply is recommended.

The drain wire on the shielded customer cable used to bring power and signal to the HYAO-1 Analog Output Module should be earth grounded only at the power supply end of the cable and **NOT** in the HYAO-1 Module.

## 9 Operation

### 9.1 Startup

After connecting the cables and applying power from the supply, the HYAO-1 delivers power to the HY-OPTIMA 5030 Series Hydrogen Sensor. Both the HYAO-1 and sensor will then execute startup sequences. The HYAO-1 boots within 30 seconds. The scaling of the analog output is done automatically based upon the sensor model type, which is automatically detected.

The HY-OPTIMA 500 sensor can take 30 minutes to 16 hours before the sensor provides accurate data. The following operations are done during the sensor startup sequence:

- Power on system self-test
- Restore configuration settings from non-volatile memory
- Start measuring oil temperature and Hydrogen
- Runs auto-calibration sequence to stabilize sensor as needed (sensor may show initial value before auto-calibration is complete)

Please refer to the HY-OPTIMA 5030 Series Hydrogen Sensor Manual (p/n 9000181) for more detailed information.

Upon startup, the HYAO-1 initiates its firmware and attempts to establish communications with the Hydrogen sensor. The status is indicated with the front panel LEDs.

## 9.2 Front Panel LEDs

The HYAO-1 Analog Output Module has two front panel LEDs; the **Green** LED indicates power and communication status to the Hydrogen sensor. The **Blue** LED indicates service conditions for either the HYAO-1 module or the Hydrogen sensor.

**Table 4: HYAO-1 Front Panel LED Indications**

Condition	Green LED	Blue LED
No Power	OFF	OFF
Initial Power ON	Flashing *	Flashing *
HYAO-1 Communicating with Hydrogen Sensor (Normal Condition)	ON	OFF
HYAO-1 Service Condition	ON	ON
Hydrogen Sensor Service Condition		
Configuration Mode		

\* On initial power on, the flashing rate for the **Blue** and **Green** LEDs is once per second.

## 9.3 Analog Output

The HYAO-1 analog output is expressed as a 4-20 mA signal. The following table indicates functionality:

**Table 5: HYAO-1 Analog Output Indications**

Current	Condition	Service
0 mA	No cable to Hydrogen Sensor or Power Off	N/A
2 mA	Hydrogen Sensor not ready for Operation	
3 mA	HYAO-1 or Hydrogen Sensor Error †	Yes
4-20 mA	Normal Operation	No
20-24 mA*	Scaling Error Data may not be accurate but trends properly	Yes

† For General HYAO-1 or Hydrogen sensor errors, the **Blue** LED will blink once every 12 seconds.

\* If the output current is greater than 20 mA but less than 24 mA, the system will continue to operate and report data as normal. The service LED illuminates without blinking to indicate that the scaling needs to be changed.

### 9.4 Service Conditions

For service conditions for the HY-OPTIMA 5030 Series Hydrogen Sensor system, please refer to the Operating Manual (p/n 9000181).

The following Conditions will cause the HYAO-1 Analog Output Module to display a service condition and turn on the **Blue** LED.

**Table 6: HYAO-1 Service Conditions**

Condition	Action Necessary to Remedy
The analog output signal is greater than 20mA, but less than 24 mA	Consider replacing the HY-OPTIMA sensor with one that has a higher dynamic range.  <i>The system will continue to operate and report data, but it may not be accurate. Trend data will be appropriate.</i>
The calculated analog output signal is greater than 24 mA	Replace HY-OPTIMA sensor with one rated for a higher dynamic range
The HYAO-1 loses communication to the Hydrogen Sensor	The system will automatically retry to establish communications. If this becomes problematic, check wiring and grounding.  If the problem persists, contact technical support at <a href="mailto:help@h2scan.com">help@h2scan.com</a> .

## 10 Re-Sealing the HYAO-1

After the HYAO-1 unit has been installed, wired, and configured, the checklist below should be followed to ensure that the module will seal properly and operate without issue.

- ✓ Make sure that no LEDs are flashing. Flashing indicates that there is an issue that should be resolved before leaving the installation site.
- ✓ Make sure that the **Blue** service LED is not illuminated by resolving the service condition(s).
- ✓ Make sure that the wires are properly dressed and secured with cable ties.
- ✓ Before closing the cover, install the provided desiccant package into the unit and the wooden golf tee for future re-configurations.
- ✓ Carefully close the cover ensuring that none of the wires are pinched between the cover and enclosure.
- ✓ Securely tighten the two captive cover screws to compress the cover into the gasket. (1.13 N\*m / 10 in\*lbf)
- ✓ Re-secure the latch by rotating it towards the enclosure and depress it until it clicks.

## 11 Troubleshooting

The following is a guide is to be used to help resolve some of the common issues.

**Table 7: HYAO-1 Troubleshooting Guide**

Condition	Possible Cause	Remedy
Unit is not working properly	Loose wires	Check and re-secure wires into the connectors
	Impedance mismatch on analog output	Confirm 250 Ohms or less
The Window is fogged from the inside	The desiccant pack is saturated with moisture	Replace the Desiccant pack

## 12 Unique LED Patterns

The following is a guide is to be used to help resolve some of the common problems.

**Table 8: HYAO-1 Unique LED Patterns Guide**

Condition	Possible Cause	Remedy
Blue LED flashing 1x every 12 seconds	HY-OPTIMA 5030 Series Error	Power cycle HYAO-1 and sensor. If problem persists, replace HY-OPTIMA 5030 Series
Blue LED flashing 2x every 12 seconds	HYAO-1 Memory Save Error	Reconfigure oil type and analog output scaling <i>If persistent, replace HYAO-1</i>
Blue LED flashing 5x every 12 seconds	RAM Information is not valid	Power cycle the HYAO-1

### 13 Analog Output Range Information

The following table is for reference only and is provided to show examples of scaling of the analog output for an oil calibrated sensor.

<b>Model</b>	<b>Range (%)</b>	<b>4 mA = %</b>	<b>20 mA = %</b>	<b>24 mA = %</b> Overscale, Service
Hy-Optima <b>5031</b>	0 to 10 % H <sub>2</sub>	0	10	12.5
Hy-Optima <b>5032</b>	0 to 5 % H <sub>2</sub>	0	5	6.25
Hy-Optima <b>5033</b>	0 to 100 % H <sub>2</sub>	0	100	125
Hy-Optima <b>5034</b>	0 to 100 % H <sub>2</sub>	0	100	125
Hy-Optima <b>5020</b>	0 to 5 % H <sub>2</sub>	0	5	6.25

**Table 9: HYAO-1 Analog Output Range Information**

# HYAO-1 Analog Output Module Installation and Configuration *Quick-Start* Guide

## START HERE



### 4 Mounting HYAO-1 Using 4x #10 Stainless Steel Screws and star washers (Included) DO NOT OVER TIGHTEN

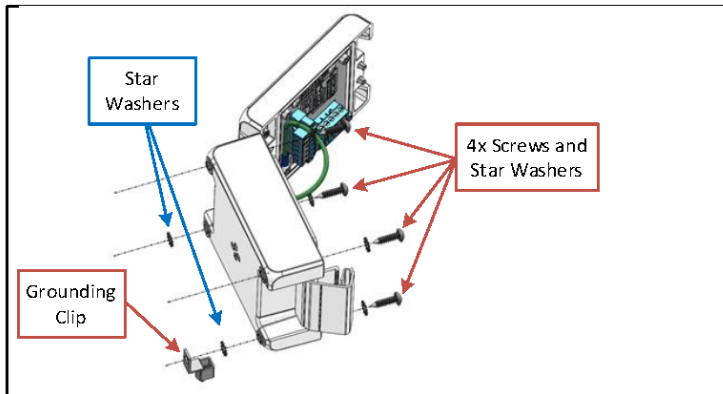

Turn Page Over to Continue

### 1 What's in the Box?

- |  |                           |
|--|---------------------------|
| >1 HYAO-1 Analog Output Module   | >1 Flat Blade Screwdriver |
| >1 pk containing 4 ea #10 Stainless Steel Sheet Metal Screws and 6 ea Star Washers | >1 3 mm Hex-L-Key         |
| >1 External Grounding Kit  | >1 Desiccant Pack         |
| >2 Wiring Connectors that mate to the PCBA   | >7 Cable Ties             |
| >1 pk containing 1 ea screw and washer for internal cable shield grounding         | >1 Quick-Start Guide      |



### 2 Tools Required

- > Portable Drill - For Drilling Pilot Holes and Driving Mounting Screws
- > 3mm (0.125") Drill Bit - For Drilling Pilot Holes Into Metal
- > Bit Extender - For Driving Mounting Screws
- > #2 Phillips Drive Bit - For Driving Mounting Screws with Drill
- > #2 Phillips Screw Driver - For Driving Screw for Cable Shield Ground
- > Adjustable Wrench - For Tightening Gland Fittings
- > Wire Stripper - For Preparing Wires for Connection
- > Wire Cutters - For Cutting Wires to Length and Trimming Cable Ties
- > Marker or Pencil - To Mark Hole Locations and Wire Cut Lengths



### 3 1:1 Plot for Mounting the HYAO-1

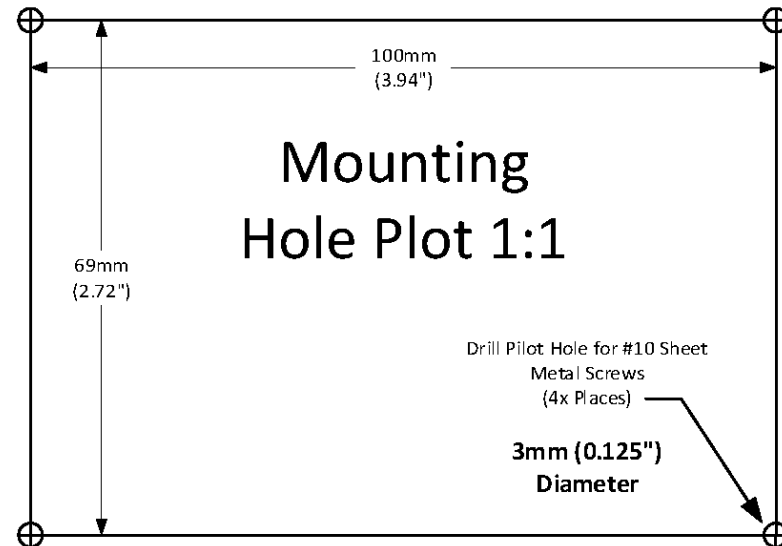

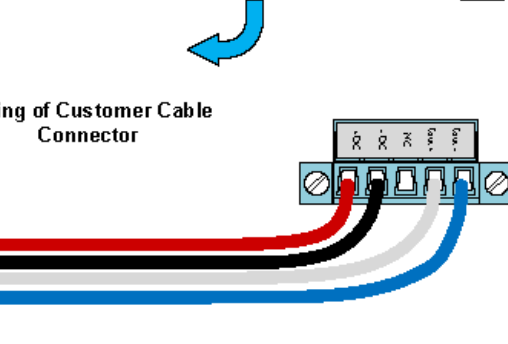
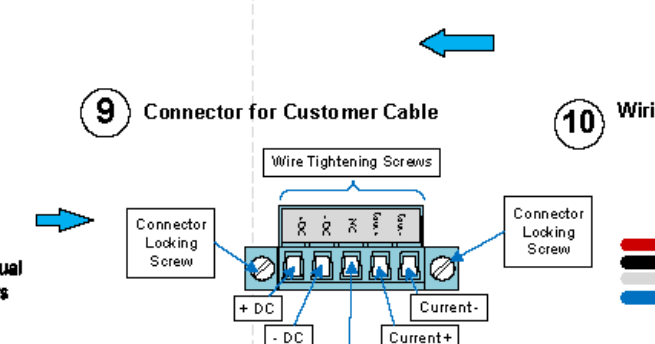
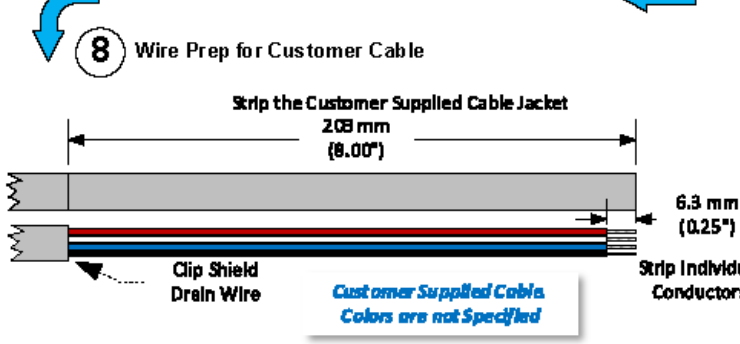
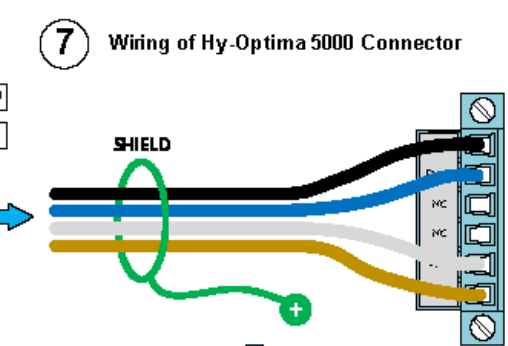
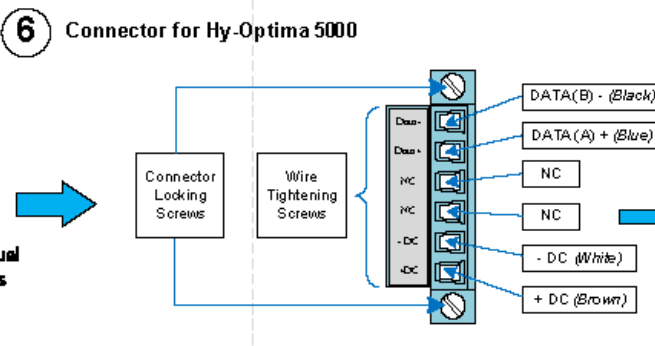
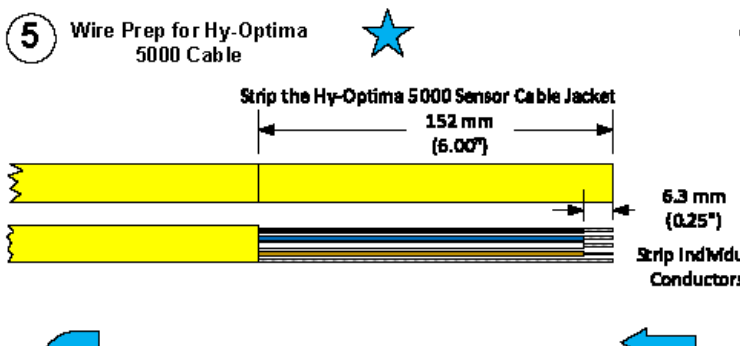

### 12 Scaling by Model

Model	Range (%)	4 mA = %	20 mA = %	24 mA = % Overscale, Service
Hy-Optima 5031	0 to 10 % H <sub>2</sub>	0	10	12.5
Hy-Optima 5032	0 to 5 % H <sub>2</sub>	0	5	6.25
Hy-Optima 5033	0 to 100 % H <sub>2</sub>	0	100	125
Hy-Optima 5034	0 to 100 % H <sub>2</sub>	0	100	125
Hy-Optima 5020	0 to 5 % H <sub>2</sub>	0	5	6.25

### 11 Customer Wiring Terminations (Not in HYAO-1)

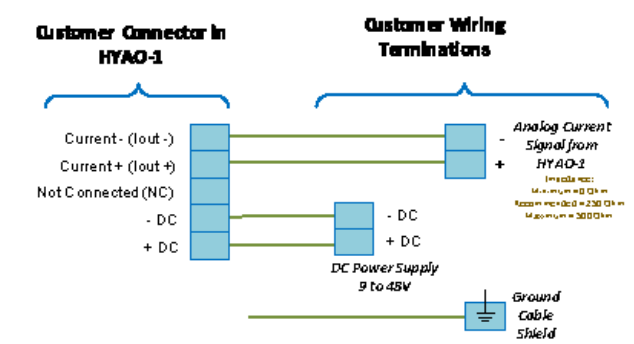

### 13 Technical Support

[help@h2scan.com](mailto:help@h2scan.com)

