

H2scan[®]

Advanced Hydrogen Sensing

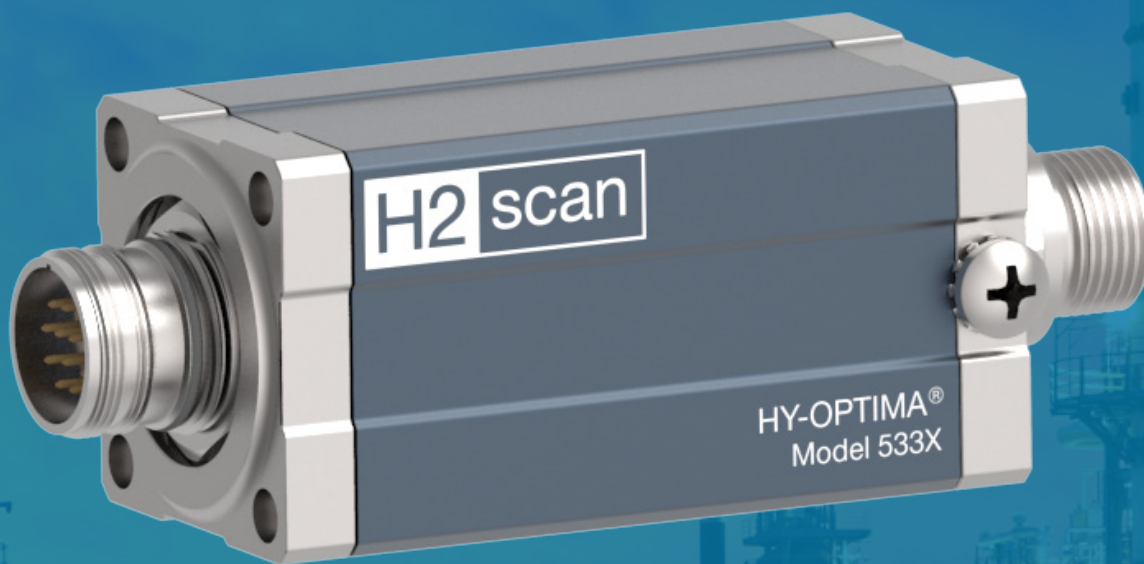

OPERATION MANUAL

HY-OPTIMA[®]

5330 Series Hydrogen Analyzers

27215 Turnberry Lane, Suite A
Valencia, California 91355, U.S.A.

Tel: (661) 775-9575 / Fax: (661) 775-9515
E-mail: hello@h2scan.com
Website: www.h2scan.com

IMPORTANT NOTICES

Read and understand this operation manual before installing or using the unit. If this equipment is used in a manner not specified by H2scan, the warranty may be void. If the equipment is used in a manner not specified by the manufacturer, the protection provided by the equipment may be impaired.

WARNING

If the product seems defective, **DO NOT** attempt to repair it. Immediately send the product back to H2scan for repairs.

LIMITATION OF LIABILITY - seller shall under no circumstances be liable for any incidental, consequential, special, punitive, or other damages, including, but not limited to, loss of business or profit, promotional or manufacturing expenses, injury to reputation, or loss of customer, based on any alleged negligence, breach of warranty, strict liability, breach of contract, or any other legal theory arising out of the use, misuse, purchase, sale or possession of its goods or its performance of this contract to the extent that such liability extends seller's obligations beyond the price paid by buyer to seller for the item on which such claim is based. Seller advises buyer to perform acceptable tests on all hardware prior to deployment and to perform maintenance as described in the seller's instruction guide. Under no circumstances shall the equipment provided hereunder be used in a manner where it is the sole protective system for facilities, equipment, and personnel safety; the equipment is intended for use in conjunction with other appropriate protective systems.

LIMITED WARRANTY

H2scan Limited Warranty: Each HY-OPTIMA® 5330 Series Hydrogen Analyzer ("Product") will conform, as to all substantial operational features, to the Product specifications set forth in this Manual and will be free of defects which substantially affect such Product's performance for 36 months from the ship date for such Product.



Must Provide Notice of Defect: If you have a Product that you believe is defective, you must notify H2scan in writing, within the warranty period of your claim regarding any such defect.

Return Product to H2scan for Repair, Replacement or Credit: The customer is responsible for shipping and handling costs. If the Product is found defective by H2scan, H2scan's sole obligation under this warranty is to either (i) repair the Product, (ii) replace the Product, or (iii) issue a credit for the purchase price for such Product, the remedy to be determined by H2scan on a case-by-case basis. A valid RMA number must be assigned by H2scan and clearly marked on the package when the unit is returned.

Voided Warranty: H2scan's three-year Limited Warranty is void for any of the following:

- Unauthorized repair work performed at the customer's location or conducted by anyone other than H2scan's factory trained technicians.
- Equipment or parts that have been tampered with, misused, neglected, mishandled, improperly adjusted, or modified in any way without the written consent of H2scan.
- Equipment or parts that have been damaged due to shipping, misuse, accidents, mishandling, neglect, or problems with electrical power sources.
- Repair work performed during the warranty period does not prolong the warranty period past the original period.
- System operation in incorrect or inappropriate environments.
- Usage that is not in accordance with system guidelines or an operator's failure to follow manual instructions.

Limitation of Warranty: THE ABOVE IS A LIMITED WARRANTY AS IT IS THE ONLY WARRANTY MADE BY H2SCAN. H2SCAN MAKES NO OTHER WARRANTY EXPRESS OR IMPLIED AND EXPRESSLY EXCLUDES ALL WARRANTIES OF MERCHANTABILITY AND FITNESS FOR A PARTICULAR PURPOSE. YOUR SOLE REMEDY HEREUNDER IS REPAIR OR REPLACEMENT OF THE PRODUCT OR A CREDIT FOR THE PURCHASE PRICE FOR SUCH PRODUCT, THE PARTICULAR REMEDY TO BE DETERMINED BY H2SCAN ON A CASE-BY-CASE BASIS. H2SCAN SHALL HAVE NO LIABILITY WITH RESPECT TO ITS OBLIGATIONS UNDER THIS AGREEMENT FOR CONSEQUENTIAL, EXEMPLARY, OR INCIDENTAL DAMAGES, EVEN IF IT HAS BEEN ADVISED OF THE POSSIBILITY OF SUCH DAMAGES. THE STATED EXPRESS WARRANTY IS IN LIEU OF ALL LIABILITIES OR OBLIGATIONS OF H2SCAN FOR DAMAGES ARISING OUT OF OR IN CONNECTION WITH THE DELIVERY, USE OR PERFORMANCE OF THE PRODUCTS.

Symbol	Meaning
	CE marking according to the current applicable directive.
	According to its marking, the device is certified for hazardous areas.
	Safety instructions that must always be followed: The respective data must be noted and/or the safety-related instructions contained in the operating instructions must be followed for devices with this symbol!

1. INTRODUCTION	6
2. PRE-INSTALLATION REQUIREMENTS	6
2.1 PACKING LIST	6
2.2 TOOLS FOR MOUNTING AND COMMISSIONING	6
2.3 OPTIONAL ACCESSORIES	6
2.4 GAS CONNECTION	7
2.5 CABLING AND WIRING	7
2.6 INTERFACE BARRIERS	7
2.6.1 Power Supply Barrier	8
2.6.2 RS-485 Communication Barrier	9
2.6.3 Analog Output Barrier	9
2.6.4 Digital Output Barrier	9
3. INSTALLATION.....	10
3.1 MECHANICAL CONNECTION	10
3.2 ELECTRICAL CONNECTION	11
3.3 EARTH GROUND CONNECTION	12
4. COMMISSIONING	12
4.1 STARTUP	12
4.2 TWO-POINT FIELD CALIBRATION.....	13
4.2.1 Calibration Gases.....	13
4.2.2 Background Gases.....	13
4.2.3 Field Calibration Procedure.....	14
4.2.4 Abort Field Calibration	15
4.2.5 Calibration Status and Errors	15
5. OPERATION	16
5.1 MONITORING.....	16
5.1.1 RS-485	16
5.1.2 Analog Output	16
5.1.3 Digital Output	16
5.2 SHUTDOWN.....	16
5.3 ERROR/EXCEPTION HANDLING	17
5.4 ATMOSPHERE-INDUCED ERRORS.....	17
5.4.1 5331, 5333, 5334	17
5.4.2 5332	17
5.4.3 Non-Reducing and Non-Oxidizing Atmospheres	17
5.5 EFFECT OF PRESSURE	18
5.6 PRESSURE-NORMALIZED OPERATION	18
5.7 VARIABLE-PRESSURE OPERATION	18

APPENDIX A: SPECIFICATIONS..... 18

APPENDIX B: CSA COMPLIANCE & CERTIFICATIONS..... 21

APPENDIX C: OTHER STANDARDS 31

APPENDIX D: TROUBLESHOOTING 31

1. INTRODUCTION

The HY-OPTIMA 5330 Series Intrinsically Safe Hydrogen Analyzers for hazardous locations measure hydrogen concentration in mixed gases without cross sensitivities to hydrocarbons, carbon dioxide, and inert gases, and to limited concentrations of carbon monoxide and hydrogen sulfide.

Using H2scan’s patented solid-state, non-consumable, hydrogen-specific sensing element as well as patented algorithms and a robust design, the analyzers report accurate hydrogen readings through a digital interface — without periodic calibration. If used in typical industrial streams under normal operation following the guidelines in this manual, expect the measurement algorithm to maintain its stated accuracy over the life of the device.

This product series improves efficiency/yields and provides safe, effective operations for real-time, in-line petrochemical processing and hydrogen economy applications, such as electrolyzers and fuel cells as well as hydrogen distribution, blending, and storage.

IP66-rated as fully dust-tight and protective against direct high-pressure jets, the HY-OPTIMA 5330 Series Hydrogen Analyzers have a rugged, waterproof mechanical assembly design for industrial applications.

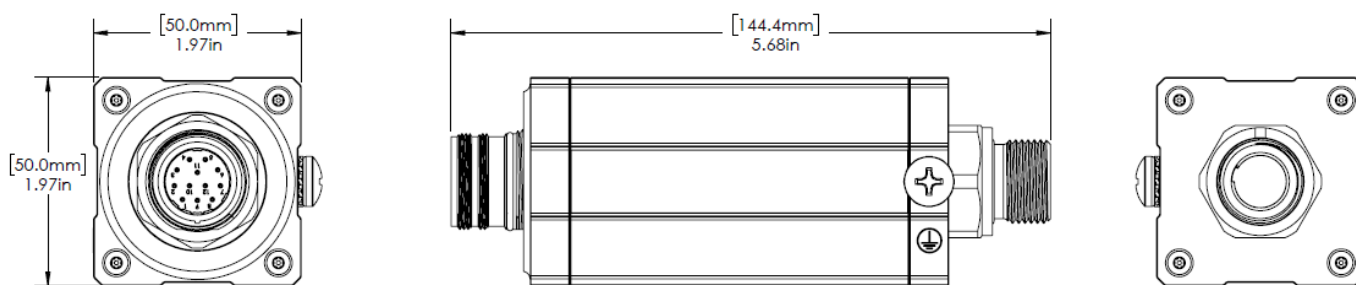

Figure 1: HY-OPTIMA 5330 Series Hydrogen Analyzer Dimensions

2. PRE-INSTALLATION REQUIREMENTS

2.1 PACKING LIST

Every HY-OPTIMA 5330 Series Hydrogen Analyzer is shipped with the following:

- Grounding hardware
- 5 m cable

NOTE: The safety of any system incorporating the equipment is the responsibility of the assembler of the system.

2.2 TOOLS FOR MOUNTING AND COMMISSIONING

The end user must provide the following tools:

- #2 Phillips head drive screwdriver
- Adjustable wrench to tighten gas plumbing fittings
- Wire cutters to trim wires to length and trim cable ties
- Wire strippers to prepare wires for connection

2.3 OPTIONAL ACCESSORIES

Various accessories are available for purchase prior to installation. Visit the H2scan HY-OPTIMA 5330 Series Hydrogen Analyzer Accessories page.

2.4 GAS CONNECTION

As user applications and installations may vary, H2scan has made available various gas connection adapter accessories that adapt from the standard M20 thread connection on the HY-OPTIMA 5330 Series Hydrogen Analyzer. These adapters include:

- M20 to 1/2" NPT
- M20 to 3/4" NPT
- M20 to 3/4" tube (for compression fittings)

These adapters may be purchased with any HY-OPTIMA 5330 Series Hydrogen Analyzer.

2.5 CABLING AND WIRING

The H2scan cable shipped with your product has been specially designed and manufactured to the requirements of intrinsic safety. The H2scan cable assembly is available in lengths of 5, 10, 20, or 30 m. For cable assembly pinout and wiring information refer to 3.2 Electrical Connection, Figure 3.

2.6 INTERFACE BARRIERS

When operated in a hazardous area, the HY-OPTIMA 5330 Series Hydrogen Analyzer must be connected to Ex i certified barriers located in a non-hazardous area using the H2scan-supplied cable. The maximum length of cable for intrinsically safe operation is 30 m. The analyzer safety interface parameters are listed in [Table 1](#).

Table 1: HY-OPTIMA 5330 Series Hydrogen Analyzer Safety Interface Parameters

Input Parameters	Output Parameters
Pins 1 & 2 (Power Supply)	
Maximum $U_i = 15.6$ V	N/A
Maximum $I_i = 160$ mA	N/A
Maximum $P_i = 2$ W	N/A
Maximum $C_i = 10$ nF (without cable) or 22 nF (with 30 m cable)	N/A
Maximum $L_i = 36.11$ μ H (without cable) or 169 μ H (with 30 m cable)	N/A
Pins 4,5, & 11 (RS-485)	
Maximum $U_i = 6$ V	Maximum $U_o = 6.52$ V
Maximum $I_i = 160$ mA	Maximum $I_o = 330$ mA
Maximum $P_i = 150$ mW	Maximum $P_o = 537$ mW
Maximum $C_i = 7.5$ μ F (without cable) or 7.8 μ F (with 30 m cable)	Maximum $C_o = 3.5$ μ F (without cable) or 3.4 μ F (with 30 m cable)
Maximum $L_i = 1$ μ H (without cable) or 133 μ H (with 30 m cable)	Maximum $L_o = 163.25$ μ H (without cable) or 30.25 μ H (with 30 m cable)
Pins 6 & 7 (Analog Output)	
Maximum $U_i = 28$ V	N/A
Maximum $I_i = 100$ mA	N/A
Maximum $P_i = 750$ mW	N/A
Maximum $C_i = 69$ nF (without cable) or 81 nF (with 30 m cable)	N/A
Maximum $L_i = 1$ μ H (without cable) or 133 μ H (with 30 m cable)	N/A

Input Parameters	Output Parameters
Pins 8, 9, & 12 (Digital Output)	
Maximum $U_i = 10\text{ V}$	N/A
Maximum $I_i = 40\text{ mA}$	N/A
Maximum $P_i = 200\text{ mW}$	N/A
Maximum $C_i = 10\text{ nF}$ (without cable) or 34 nF (with 30 m cable)	N/A
Maximum $L_i = 1\text{ }\mu\text{H}$ (without cable) or $133\text{ }\mu\text{H}$ (with 30 m cable)	N/A

The following barriers are recommended to use with the HY-OPTIMA 5330 Series Hydrogen Analyzer for an Intrinsically Safe implementation (refer to individual manufacturer’s data sheets for proper connection and operation):

Intrinsically Safe Power Barrier: R. STAHL, INC. Ex I Power Supply, P/N 9143/10-156-160-10s

Intrinsically Safe Serial Interface Barrier (RS-485): R. STAHL, INC. Fieldbus Isolating Repeater, P/N 9185/11-35-10s

Intrinsically Safe Analog Output Barrier (4–20 mA): R. STAHL, INC. Transmitter Supply Unit, Ex i Field Circuit, P/N 9160/13-11-11s

Intrinsically Safe Digital Output Barrier: R. STAHL, INC. Switching Repeater, Ex i Field Circuit, P/N 9170/21-11-11s

CAUTION

This equipment shall only be powered by a limited energy electric circuit in accordance with CAN/CSA C22.2 No. 61010-1-12 and ANSI/UL 61010-1, or Class 2 as defined in the Canadian Electrical Code C22.1, Section 16-200 and/or National Electrical Code (NFPA 70), article 725.121, when installed in non-hazardous areas.

2.6.1 Power Supply

Each HY-OPTIMA 5330 Series Hydrogen Analyzer incorporates an internal voltage regulator for operation in harsh electrical conditions. An external DC power source is required to energize the analyzer for operation. As required for intrinsic safety, power must be limited in the hazardous area using an Ex i certified barrier that meets the following specifications:

Use an Ex i power supply barrier that meets the following specifications:

- Maximum acceptable output voltage [U_o] $\leq 15.6\text{ V}$
- Maximum acceptable output current [I_o] $\leq 160\text{ mA}$
- Maximum acceptable output power [P_o] $\leq 2\text{ W}$
- Permissible equivalent external capacitance [C_o] $\geq 22\text{ nF}$
- Permissible equivalent external inductance [L_o] $\geq 169\text{ }\mu\text{H}$

DC power is electrically isolated from the metal enclosure of this device.

The metal enclosure of this device shall be connected to the earth safety ground as described in [Appendix B](#).

2.6.2 RS-485 Communication

HY-OPTIMA 5330 Series Hydrogen Analyzers offer digital communication using Modbus over a three-wire, half-duplex RS-485 interface that is galvanically isolated. Fail-safe resistors and a 120 Ohm termination resistor are installed in the analyzer. As required for intrinsic safety, power transferred through these signals must be limited in the hazardous area using an Ex i certified barrier that meets the following specifications:

- Maximum acceptable output voltage [Uo] ≤ 6 V
- Maximum acceptable output current [Io] ≤ 160 mA
- Maximum acceptable output power [Po] ≤ 150 mW
- Permissible equivalent external capacitance [Co] ≥ 7.8 μF
- Permissible equivalent external inductance [Lo] ≥ 133 μH
- Maximum voltage the barrier can accept from the device in case of a fault [Ui] ≥ 6.52 V
- Maximum current the barrier can accept from the device in case of a fault [Ii] ≥ 330 mA
- Maximum power the barrier can accept from the device in case of a fault [Pi] ≥ 537 mW

2.6.3 Analog Output

The HY-OPTIMA 5330 Series Hydrogen Analyzers offer a 4–20 mA analog output that is powered by an external voltage source. The output current has the following properties:

- 0 mA indicates the device is disconnected or not powered
- 3.5 mA indicates an error condition
- 4–20 mA indicates the hydrogen measurement
- 22 mA indicates the device is warming up and not ready

The 4–20 mA analog output is derived from the measured hydrogen value and scaled based on the measurement range associated with each model, as shown in [Table 2](#).

Table 2: Default Measurement Range by Model Number

Model	Default Measurement Range	Warmup	Error
5331	0–10%	22 mA	3.5 mA
5332	0–5%		
5333	0–100%		
5334	0–100%		

As required for intrinsic safety, power transferred through these signals must be limited in the hazardous area using an Ex i certified barrier that meets the following specifications:

- Maximum output voltage [Uo] ≤ 28 V
- Maximum output current [Io] ≤ 100 mA
- Maximum output power [Po] ≤ 750 mW
- Permissible capacitance [Co] ≥ 81 nF
- Permissible inductance [Lo] ≥ 133 μH

2.6.4 Digital Output

The HY-OPTIMA 5330 Series Hydrogen Analyzers offer two digital outputs that share a common reference. These digital outputs are electrically isolated from the other electrical systems. They can be independently configured via Modbus to indicate high levels of hydrogen or a fault condition with the device. Typically, DOUT-1 is configured for hydrogen alarm and DOUT-2 is configured to indicate fault conditions.

The digital outputs have “open-collector” logic, which is analogous to a normally open relay. That is, when deactivated, current will not flow from DOUT to DOUT-REF. When activated, current will flow from DOUT to DOUT-REF.

When using a digital output as a hydrogen threshold alarm while the hydrogen measurement is below the alarm threshold, the digital output will be in a deactivated state and will not allow current to flow from DOUT to DOUT-REF. As soon as the hydrogen measurement exceeds the threshold, the digital output activates and allows current to flow.

When using a digital output to detect faults while no fault is detected, the digital output is activated and allows current to flow from DOUT to DOUT-REF. When a fault occurs, the digital output deactivates and stops current from flowing.

As required for intrinsic safety, power transferred through these signals must be limited in the hazardous area using an Ex i certified barrier that meets the following specifications:

- Maximum output voltage [Uo] ≤ 10 V
- Maximum output current [Io] ≤ 40 mA
- Maximum output power [Po] ≤ 200 mW
- Permissible capacitance [Co] ≥ 34 nF
- Permissible inductance [Lo] ≥ 133 μH

3. INSTALLATION

CAUTION

Avoid damage to the analyzer assembly during handling by:
Ensuring nothing comes in contact with the sensor end of the device.
Keeping the cap in place until installation.

3.1 MECHANICAL CONNECTION

WARNING

Do not subject the analyzer to high-impact forces or tamper with the seals. Doing so may damage the wetted barrier.

1. If required, install an M20 gas connection adapter.
2. Ensure the adapter is appropriately torqued to the analyzer M20 fitting until metal-to-metal contact is made between the bottom of the adapter and the flange of the M20 fitting. This will ensure the o-ring maintains a gas-tight connection.

NOTE: Various adapters are available as accessories for different user applications and installations. A recommended torque is provided with each adapter.

Ensure a gas-tight connection between the HY-OPTIMA 5330 Series Hydrogen Analyzer and the end user plumbing to maintain hazardous location requirements.

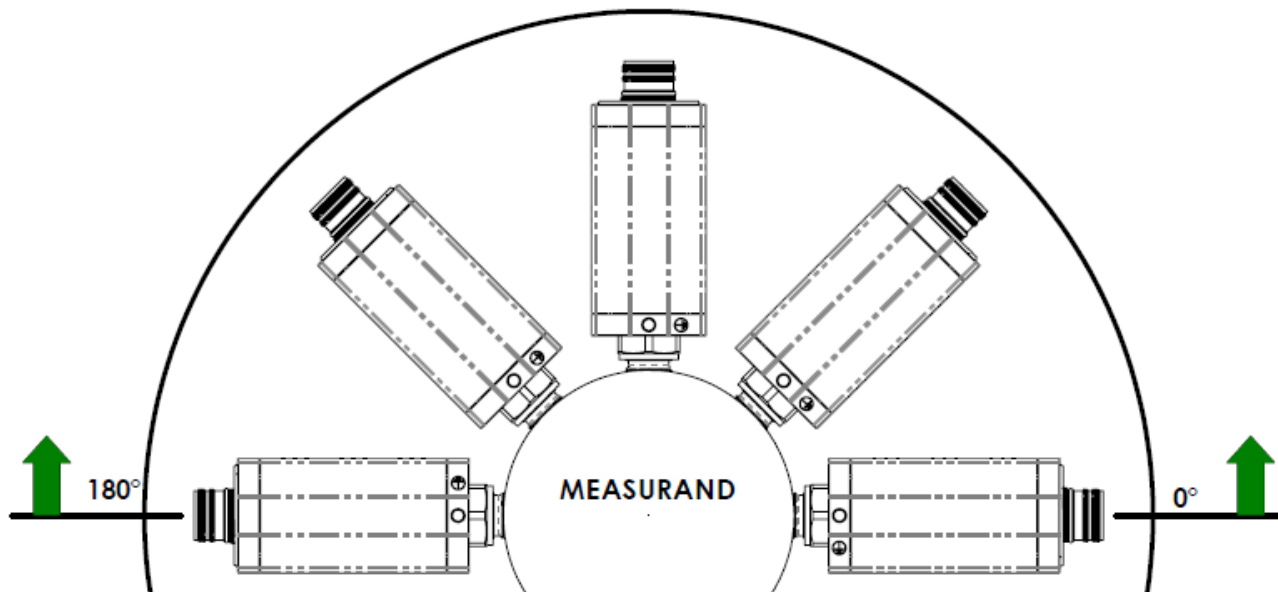

Figure 2: Acceptable Mounting Orientations

⚠ WARNING

Mounting the analyzer such that the sensor cavity accumulates condensed liquids will damage the sensor and void the warranty.

3.2 ELECTRICAL CONNECTION

Electrical connection to the HY-OPTIMA 5330 Series Hydrogen Analyzer is achieved through a single connector using an H2scan cable assembly. Using a different cable assembly may degrade performance and safety of the installation.

Make all electrical connections to associated equipment (barriers and power supply) before connecting cable to the analyzer. The cable includes four separate circuits (DC Power, RS-485, Analog Output, Digital Outputs). Wires within each circuit have unique colors however, the same color wire is used in different circuits. To ensure proper connection it is important to check continuity from connector pin to wired connection. The following figure identifies the cable pinout, and wire colors. Use the following check list to complete wiring:

1. Route cable from analyzer to associated equipment, confirm sufficient length.
2. Dress flying leads as needed to route wires to terminals, any unused wires/circuits must be secured and isolated.
3. Connect two wires to the Intrinsically Safe Power Barrier, confirm polarity.
4. Connect three wires to the Intrinsically Safe Serial Interface Barrier (RS-485), confirm polarity of signal wires, connect RS485-GND to the ground reference.
5. Connect two wires to the Intrinsically Safe Analog Output Barrier (4–20 mA), confirm polarity of signal wires.
6. Connect three wires to the Intrinsically Safe Digital Output Barrier with a jumper between (-) terminals to DOUT-REF wire, confirm polarity of connections.
7. Check continuity of all connections to the respective pins at the connector.

Attach connector to the analyzer before energizing the system. The connector must be fully engaged and hand tightened.

PIN CONFIGURATION AND FUNCTION DESCRIPTIONS			
NO.	MNEMONIC	FUNCTION	WIRE COLOR
1	VDC	Positive Supply Voltage.	BROWN
2	VDC_GND	Ground Reference for Supply Voltage. This pin must be connected to 0V with respect to VDC.	WHITE
3	NIC	Not Internally Connected. This pin is not connected to the internal circuitry.	-
4	RS485-A	RS-485 Noninverting Driver Output/Receiver Input.	BLUE
5	RS485-B	RS-485 Inverting Driver Output/Receiver Input.	BLACK
6	AOUT+	Analog Output Current.	BLUE
7	AOUT-	Analog Output Return.	GREY
8	DOUT-1	Digital Output 1 (Open Collector).	GREEN
9	DOUT-2	Digital Output 2 (Open Collector).	WHITE
10	NIC	Not Internally Connected. This pin is not connected to the internal circuitry.	-
11	RS485-GND	RS-485 Ground Reference.	GREY
12	DOUT-REF	Ground Reference for Digital Outputs 1-2.	YELLOW

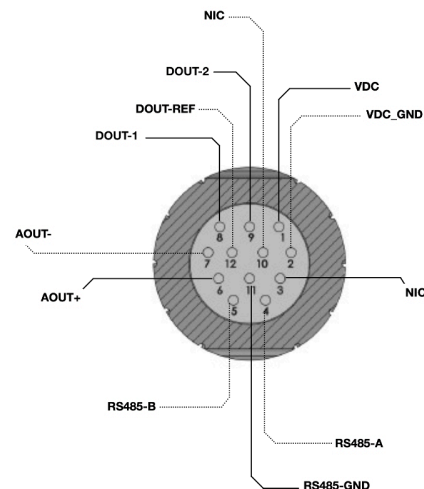

Figure 3: H2scan Cable Pinout and Wire Colors

NOTE: The connector to the HY-OPTIMA 5330 Series Hydrogen Analyzer must be fully engaged and hand-tightened to ensure the IP66 rating.

3.3 EARTH GROUND CONNECTION

The metal enclosure of this device shall be connected to the earth ground through the earth ground connection described in [Appendix B](#).

4. COMMISSIONING

NOTE: If operating at a pressure other than 1.0 ATA, the hydrogen reading must be compensated by performing a two-point field calibration or by dividing the hydrogen reading by the known pressure in ATA. See [4.2](#) for two-point field calibration instructions.

4.1 STARTUP

Power on the analyzer before flowing gas across the sensor. Once powered on, the analyzer will execute a startup sequence and begin reporting hydrogen after approximately 90 seconds. During this period, the analyzer will:

- Perform a power on system self-test
- Restore configuration settings from non-volatile memory

If the analyzer is being powered on for the first time or has been in storage for more than a week, the hydrogen measurement may initially be inaccurate due to oxygen absorption on the sensor. The model 5332 is designed for this mode of operation, but other models require a steady hydrogen exposure to remove this absorbed oxygen and drift the analyzer reading continually downward until it reaches the true hydrogen concentration. See [5.4](#) for more information.

A two-point field calibration ([4.2](#)) is recommended as part of the commissioning process to account for differences in gas stream parameters, especially pressure, from the factory calibration.

If using Modbus, the default communication settings are:

- RS-485, half-duplex, 19200 baud, 8 data bits, 2 stop bits, no parity
- Default Modbus ID is 1

The Modbus status register 111 bit 15 will indicate Ready when the first valid hydrogen measurement is available. After the startup sequence completes, measurement data will be available in the Modbus registers.

If an error is reported, turn off power to the analyzer and check the electrical connections and power supply voltage before restoring power. If the error persists, contact H2scan customer service at technicalsupport@h2scan.com.

4.2 TWO-POINT FIELD CALIBRATION

It is strongly recommended to condition the gas stream at the analyzer to have a stable operating pressure and constant flow. Even if the system is designed to operate at 1.0 ATA (matching factory calibration), a two-point field calibration is recommended upon installation for best measurement accuracy (especially if measuring high hydrogen concentrations) and to remove any measurement error due to small offsets in pressure.

If operating at constant pressure other than 1.0 ATA, a two-point field calibration can normalize the hydrogen reading. By applying two known gas concentrations, the analyzer will calculate and apply a gain and offset to its measurements to match its hydrogen reading with the known gas concentrations.

⚠ WARNING

Do NOT use gases with a hydrogen concentration exceeding 10% at 1.0 ATA for the 5331 or 5% at 1.0 ATA for the 5332.

4.2.1 Calibration Gases

Two calibration gases are required: one high and one low. Primary standard ($\pm 0.02\%$) tolerance is recommended. The given accuracy specification of the analyzer does not include the error of the calibration gas certification and is only valid with an exposure time of at least 60 minutes per gas.

For best results, use a calibration gas concentration just below the lowest expected reading and just above the highest expected reading.

EXAMPLE: If the process stream is expected to operate between 61% and 78% H₂, calibration gases of 60% and 80% H₂ are ideal.

It is not necessary to use an expensive custom blend. Use whatever is readily commercially available, keeping in mind the accuracy of the gas contributes to the accuracy of the calibration.

Table 3: Calibration Gas Limits (assuming 1.0 ATA)

Model	Minimum	Maximum
5331	0.1%	10%
5332	0.4%	5%
5333	0.5%	100%
5334	0.5%	100%

⚠ WARNING

Do NOT use gases exceeding the H₂ concentration limit specified for the model as this will damage the analyzer. Do NOT use 100% air, 100% N₂, or any gas with an H₂ concentration below the LDL of the product model.

Recommended flow rate is 1.0 ± 0.2 SLPM.

Apply gases to the analyzer through user's plumbing. Confirm the system allows the calibration gases to be applied at the same pressure the analyzer sees during normal operation.

4.2.2 Background Gases

For models 5331, 5333, and 5334 operated in hydrogen with an inert gas background, the following background gases are safe:

- N₂
- Hydrocarbons (Alkanes Alkenes/Alkynes)
- CO₂
- He, Ar, etc. (Noble)

For a 5332 analyzer operated where hydrogen may be present in air or oxygen, the calibration can be performed using hydrogen in an air background or the backgrounds listed above. The recommended gases are 1% H₂ in air and 2% H₂ in air. A verification/calibration kit is available from H2scan.

4.2.3 Field Calibration Procedure

NOTE: The exposure time per gas is a minimum of 60 minutes per exposure. Exposures shorter than 60 minutes can generate erroneous calibration data.

NOTE: The calibration can be aborted at any time (See: [4.2.4](#)).

Table 4: Two-Point Field Calibration Registers

Register	Parameter	Function	Data Type	Data Range	Access
126	Calibration Gas 1, ppm H ₂	High word	32-bit binary number	0–10,000,000	R/W
127		Low word			
128	Calibration Complete/Date	High byte: Month	32-bit binary value		R/W
129		Low byte: Day Year			
130	Calibration Gas 2, ppm H ₂	High word	32-bit binary number	0–10,000,000	R/W
131		Low word			
132	Field Cal start command	Gas exposure duration (minutes)	16-bit binary number	60–1440	W
133	Field Cal abort command	Abort Field Cal or clear data	8-bit binary number	1: abort 2: clear	W
134	Field Cal get status command	High byte: Status Low byte: Error code	16-bit binary number	Tables 5 and 6	R
135	Gas start command	Gas 1 or 2 started	8-bit binary number	1: gas 1 2: gas 2	W

Read the status and error codes from register 134 after each write to the field calibration registers.

Upon calibration initiation, the status code should read '1' (in-progress).

The error code should read '0' (no errors detected) after register write until the procedure is completed. Upon completion, the status code should read '0' (success) and the error code should read '0' (no errors detected). Refer to [4.2.5](#) if an unexpected code appears.

1. Initiate calibration by writing the duration per gas exposure in minutes to register 132. The minimum time is 60 minutes per gas. Longer exposure times are preferable, up to 1440 minutes.
2. Apply the first gas to the unit at 1 SLPM.
3. If necessary, adjust the gas pressure at the analyzer to match the intended operating pressure.

NOTE: Ideally, the calibration gases are flowed through the same pressure regulation system as the measured gas stream and require no adjustment.

4. Indicate the first gas is flowing by writing '1' to register 135.

5. Wait the exposure time.
6. Write the first gas concentration in ppm to registers 126, 127. To convert percentage to ppm, multiply percentage value by 10,000.
7. Apply the second gas at 1 SLPM.
8. Ensure the gas pressure at the analyzer has not changed, making any necessary adjustments.
9. Indicate the second gas is flowing by writing '2' to register 135.
10. Wait the exposure time.
11. Write the second gas concentration in ppm to registers 130, 131.
12. Finish the field calibration with the current date by writing to registers 128, 129.
13. The unit will automatically reboot.

4.2.4 Abort Field Calibration

To abort a field calibration while in progress, either power cycle the unit or write '1' to register 133.

4.2.5 Calibration Status and Errors

Check Register 134 for calibration status and errors.

Table 5: Field Calibration Status

Code	Definition
0	The calibration was completed successfully.
1	The calibration process is ongoing.
2	The calibration failed due to errors.
3	The calibration was cancelled by the user.
4	The calibration has been removed and factory settings restored.
5	The most recent command was not executed. See the error code for more details.

Table 6: Field Calibration Errors

Code	Definition	Resolution
0	No errors detected.	N/A
2	Field calibration already in-progress.	Abort in-progress field calibration. See 4.2.4 .
3	The entered gas exposure time is outside the limits.	Ensure the time was entered in minutes and within the limits of the product (minimum of 60 minutes).
4	Internal problem with the unit.	Power cycle and try again. Contact H2scan if the error persists.
5	This code is used for diagnostic purposes only.	N/A
7	Entered gas concentration is outside limit.	Ensure the gas concentration is entered in ppm and within the range of the product model.
8	Command to start Gas 2 received before Gas 1 completed.	

Code	Definition	Resolution
10	Calibration could not complete based on measured data.	Retry the calibration. Contact H2scan if the error persists.
12	Calculated gain and/or offset are outside limits.	Confirm the gas was flowing and the concentrations entered in ppm and match the respective gases.
13	A step was skipped in the calibration process.	Restart the calibration, following the steps detailed above.
14	The gas exposure was not completed.	Retry the command once the full exposure time has elapsed. If an incorrect gas exposure time was entered, abort the field calibration and start over.

Once the calibration is complete, maintain operating pressure and do not adjust the pressure regulation to ensure the normal operating conditions match the field calibration conditions as closely as possible.

5. OPERATION

NOTE: If operating at a pressure other than 1.0 ATA, the hydrogen reading must be compensated by performing a two-point field calibration or by dividing the hydrogen reading by the known pressure in ATA. See [4.2](#) for two-point field calibration instructions.

5.1 MONITORING

5.1.1 RS-485

During normal operation, poll the HY-OPTIMA 5330 Series Hydrogen Analyzer measurements through the RS-485 interface periodically for a measurement reading. The time between readings can be from one second to several hours or days depending on user requirements. Each reading should include the following Modbus holding registers.

- Status Register (111 bits 15 and 12): Bit 15 indicates the hydrogen measurement is available. Bit 12 indicates an error.
- Error Status Registers (112,113): Indicates which error is detected. These registers are active when register 111 bit 12 is high.
- Hydrogen Registers (0,1): Provides the hydrogen ppm values. Programming note: The high word (0) must be read to enable the low word (1) value to be available.

NOTE: Regarding Hydrogen Registers (0,1), to convert ppm to %, divide ppm reading by 10,000.

5.1.2 Analog Output

The hydrogen measurement can be monitored using the analog output. See [2.6.3](#) for details.

5.1.3 Digital Output

Two isolated digital outputs can be used as alerts to signal high levels of hydrogen as well as fault conditions within the electronics. See [2.6.4](#) for electrical information. For configuration details, consult the Modbus Register Map, which is available as a separate document.

5.2 SHUTDOWN

1. Purge the system using gas with a hydrogen concentration of less than 5% H₂ or with 100% N₂ for five minutes.

NOTE: For the 5332 model, hydrogen-free gases such as air or inert gases such as nitrogen, argon, or helium can be used.

2. Turn off all gas flow to the analyzer.
3. Power off the analyzer.

5.3 ERROR/EXCEPTION HANDLING

The HY-OPTIMA 5330 Series Hydrogen Analyzers are designed for continuous operation and will automatically recover from intermittent problems due to insufficient power, excessive electrical noise, or excessive internal ASIC temperature.

An internal algorithm maintains long-term measurement accuracy without periodic field calibrations. For this algorithm to run properly, the analyzers must be powered on continuously. If the analyzer is powered on only for durations less than two hours, the algorithm will not function properly and the analyzer accuracy may not meet the product specifications.

If the sensor element is damaged and unable to operate, the HY-OPTIMA 5330 Series Hydrogen Analyzer will shut down the measurement system and continue responding to Modbus for error reporting. This error will be reported via register 111 bit 12 with details specified in register 112,113. This type of error typically indicates a hardware fault that can only be repaired at H2scan. Power cycle the unit to attempt recovery. If the error condition persists, contact H2scan for repair at technicalsupport@h2scan.com.

5.4 ATMOSPHERE-INDUCED ERRORS

5.4.1 5331, 5333, 5334

If HY-OPTIMA models 5331, 5333, and 5334 are left on for periods of time in a gas containing oxygen and less than ~300 ppm of hydrogen, an oxide layer will form on the surface of the analyzer and an oxygen offset will occur.

The more oxygen to which the analyzer is exposed, the faster and stronger the offset will be. Oxygen offset varies by analyzer. This physical offset will not appear in the reported H₂ because an internal algorithm will remove the effect. Exposure to H₂ after the oxygen offset may temporarily reduce accuracy and delay response time.

Small amounts of H₂ (1,000 ppm, for example) should ensure no offset occurs even in atmospheres containing oxygen (tested in air, up to 20% O₂). Higher oxygen contents may require larger amounts of H₂ to prevent oxidation.

The oxide layer must be fully removed before the analyzer will respond to hydrogen.

1. Purge the analyzer with H₂ to remove the oxide layer.
2. Wait for the algorithm to automatically correct for the offset.

Correction time depends on the magnitude of the oxidation offset, the concentration of the hydrogen removing the offset, and the stability of the system. Generally, two hours in a constant H₂ concentration is sufficient.

WARNING

Do not exceed the maximum specified H₂ concentration for the given model.

5.4.2 5332

The HY-OPTIMA 5332 Analyzer is designed for H₂ exposure of less than a few hours at a time, e.g., leak detection applications. While the analyzer is capable of continuous H₂ exposure, a temporary reduction in accuracy (the device reports lower H₂ content) three to six hours after the start of the continuous H₂ exposure may occur when the H₂ bonds with oxygen on the analyzer surface. Once the O₂ on the analyzer is completely depleted (a process that can take several hours, depending on the H₂ concentration), an internal algorithm will correct the measurement and allow the analyzer to measure accurately in the continuous H₂.

5.4.3 Non-Reducing and Non-Oxidizing Atmospheres

The analyzer experiences drift when powered on in a gas containing no hydrogen or oxygen for days or longer. While an internal algorithm ensures the reported H₂ remains at zero, eventual exposure to H₂ above the

lower detection limit will cause an inaccurate initial response. An internal algorithm will restore the accuracy if exposed to any constant H₂ concentration (within the range of the model) for at least four hours.

5.5 EFFECT OF PRESSURE

Changes in overall gas pressure affect the analyzer's measurement of hydrogen partial pressure.

While the analyzer is not directly sensitive to fluctuations in gas temperature, temperature-induced fluctuations in pressure may affect the measurement accuracy.

EXAMPLE: At 1.0 ATA, the analyzer will report a 50% H₂/N₂ as 50% by the analyzer. The reading will increase to 55% at 1.1ATA and 100% at 2.0 ATA.

HY-OPTIMA 5333 and 5334 can measure multiple atmospheres of hydrogen; readings above 100% H₂ are interpreted as hydrogen pressures above 1.0 ATA.

EXAMPLE: A 150% H₂ reading means 1.5 times the hydrogen pressure of a 100% H₂ concentration at 1.0 ATA.

5.6 PRESSURE-NORMALIZED OPERATION

Hydrogen is reported as a volumetric concentration and pressure is assumed to be constant.

A gas containing 10% hydrogen by volume at 1.0 ATA has a partial pressure of 0.1 ATA of hydrogen, while 10% hydrogen by volume at 2 ATA corresponds to 0.2 ATA of hydrogen. For more information on the subject, refer to Dalton's Law.

5.7 VARIABLE-PRESSURE OPERATION

If the pressure is known or actively measured by a pressure sensor, the volumetric H₂ concentration can be calculated using the equation below:

$$H_{2vol} = \frac{H_{2read}}{P_{ata}}$$

- P_{ata} is the known or measured pressure in ATA
- H_{2read} is the H₂ reading from the analyzer, under the assumption the analyzers using the factory calibration at 1.0 ATA

Any error in pressure measurement translates as an error in the H₂ concentration measurement. This effect is especially significant when the analyzer is measuring high hydrogen concentrations.

EXAMPLE: If an analyzer is measuring 100% H₂ at 1.00 ATA and a pressure sensor actively compensates the reading for pressure with a relative error of 1% (0.01 atmospheres), the analyzer will have a measurement error of 1% H₂.

APPENDIX A: SPECIFICATIONS

Analyzer performance specifications are absolute and assume a dry process stream, an ambient temperature of 25 °C, and 1 ATA gas pressure, and are affected by errors in the calibration gases. Accuracy and repeatability are defined as ± the values listed. For other operating pressures, see [5.5](#). For the partial limits, see [Table A.2](#).

While the analyzers can operate in gas containing no hydrogen, measurement performance specifications are valid only when the analyzer is exposed to gas containing hydrogen above the Lower Detection Limit shown in [Table A.1](#).

Table A.1: Product Selection

Model	H ₂ Range	Lower Detection Limit (LDL)	CO Limit	H ₂ S Limit	Response Time* (sec)	Gas Stream Temperature Range (°C)	Accuracy and Repeatability
5331	LDL–10% H ₂	0.03% H ₂	100 ppm	0	< 90	-20–+60	See Table A.3
5332	0–5% H ₂	0.4% H ₂	0	0	< 60	-20–+60	0.3% H ₂ (Absolute Error)
5333	LDL–100% H ₂	0.5% H ₂	100 ppm	1000 ppm	< 60	-20–+60	See Table A.4
5334	LDL–100% H ₂	0.5%	20%	3%	< 90	-20–+50	See Table A.4

*For models 5331, 5333, and 5334, the response time is defined as the 90% transition time (T90) from the model's LDL to the maximum H₂ range. For the model 5332, the response time is the time until the measured H₂ exceeds 1% when transitioning from air to 3% H₂/Air.

Table A.2: Partial Pressure Limits

Model	H ₂ Limit (ATA H ₂)	Lower Detection Limit (ATA H ₂)	CO Limit (ATA CO)	H ₂ S Limit (ATA H ₂ S)
5331	0.1	0.0003	0.0001	0
5332	0.05	0.004	0	0
5333	3	0.005	0.0001	0.0001
5334	3	0.005	0.2	0.03

Table A.3: Model 5331 Accuracy and Repeatability

H ₂ Range	Accuracy (Absolute Error)	Repeatability (Absolute Error)
LDL–0.5%	0.06%	0.06%
0.5–2%	0.15%	0.15%
2–5%	0.25%	0.25%
5–10%	0.5%	0.5%

Table A.4: Model 5333/5334 Accuracy and Repeatability

H ₂ Range	Accuracy (Absolute Error)	Repeatability (Absolute Error)
LDL–10%	0.4%	0.2%
10–30%	0.7%	0.3%
30–70%	1.0%	0.4%
70–100%	1.2%	0.5%

Table A.5: Operating Conditions

Parameter	Value			Units
	Minimum	Nominal	Maximum	
Environment – Gas Stream				
Pressure Certified, Hazardous Location CSA*	0.95	1	1.1	Bar Absolute
Pressure Survival*	0.1		10	ATA
Gas Flow Rate (1/4" tube)		1	10	SLPM
Gas Flow Velocity			8	M/S
Humidity	0		95%	RH (non-condensing)
Temperature	See Table A.1			
Environment – Ambient				
Ambient Temperature	-40		70	°C
Storage Temperature	-40		85	°C
Humidity	0		95%	RH (non-condensing)
Ingress Protection	IP66			
Altitude	0–2000 m above sea level			
Mechanical				
Vibration	ISTA 6-FEDEX-A TEST			
Shock	ISTA 6-FEDEX-A TEST			
Weight	1.65 lbs (748.43 g)			
Electrical				
Voltage Input Certified, Hazardous Location CSA	10		15.6	VDC
Power Consumption			2	W
Digital Output			10 40 200	VDC mA mW
Analog Output	3.5	4–20	24	mA
RS-485	Modbus RTU (three-wire)			

*Operating at pressures above or below 1 ATA will affect the measurement accuracy. See [5.5](#). Operating above the partial pressure limits listed in [Table A.2](#) may damage the sensor.

This equipment is capable of withstanding Overvoltage Category: II.

Pollution Degree 2: Normally only nonconductive pollution occurs. Temporary conductivity caused by condensation is to be expected. Ex. "Equipment is suitable for Laboratories, Test stations, or Office environment.

APPENDIX B: CSA COMPLIANCE & CERTIFICATIONS

CD90000240: CSA COMPLIANCE & CERTIFICATIONS

B.1 GENERAL (SECTION APPLIES TO ALL MODELS)

B.1.1 SCOPE

Intrinsically safe (Ex) Zone 0 Hazardous locations – See Entity Parameters

Class I Div 2 or Ordinary locations (Non Hazardous locations) : Electrical Rating 18VDC to 30VDC (24VDC nominal), 2W max.

B.1.2 ENVIRONMENTAL CONDITIONS

- Specification of the Pollution Degree: 2.
- Specification of the Overvoltage Category: II.
- Specification for the maximum use altitude: 2000 m above sea level.

B.1.3 GROUNDING

The external housing shall be grounded in the end application per this diagram:

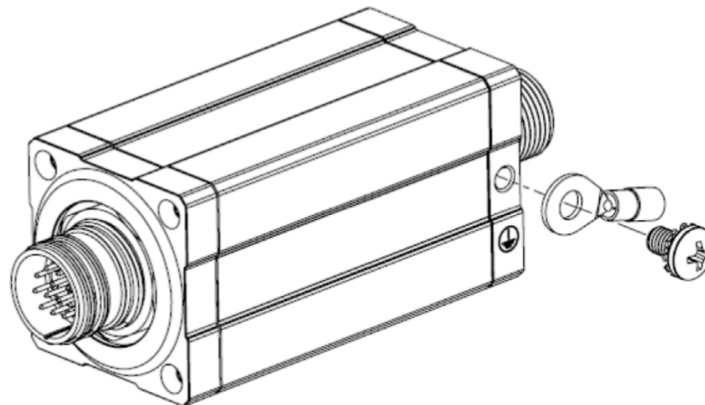

Figure 1: Earth Ground Connection

A grounding screw with an integrated external-tooth lock washer is provided with the HY-OPTIMA Hydrogen Analyzer assembly. This screw shall be used to attach a grounding lug and equivalent grounding method compliant with the standards associated with this product.

Grounding Screw Specifications:

- Size: M6 X 10mm, 18-8 Stainless Steel
- Minimum Torque: 8.7N-m (77.0 in-lbs.)

Grounding Wire Specifications:

- Minimum Grounding Conductor Size: 14 AWG Copper Wire (or equivalent as tested per UL 467)
- Use UL/CSA Listed or Recognized Wire

All of the above grounding requirements may be exempted when the following conditions are met:



- There is no insulation or coating on the mating threads of the process gas connection; and
- The process equipment is grounded according to the local electrical code

B.1.4 CERTIFICATE NUMBERS

- IECEx CSA 24.0040X
- CSANe 24ATEX1173X
- CSA24CA80204834X

B.1.5 SYMBOLS

Symbols related to safety which are used on this equipment:

- ISO 3864 Symbol B.3.1  or ISO 7000 symbol 0434  (triangle with exclamation point) with a statement that the manual must be consulted in all cases where this symbol is marked, in order to find out the nature of the potential HAZARDS and any actions which have to be taken to avoid them.

Symbol	Reference	Description
	ISO 7000-0434B (2004-01)	Caution

Exterior protective earth, for installer:

Symbol	Reference	Description
	IEC 60417-5019 (2006-08)	Protective Conductor Terminal

B.1.6 STANDARDS

This equipment has been evaluated and tested in accordance with:

Standard	Description
CAN/CSA C22.2 No. 94.2:20 ANSI/UL 50E-2020 Third Edition	Enclosures for Electrical Equipment, Environmental Considerations
CAN/CSA C22.2 No. 61010-1-12 + UPD1:2015, UPD2:2016, AMD 1 – 18 ANSI/UL 61010-1-2018 Third Edition	Safety Requirements for Electrical Equipment for Measurement, Control, and Laboratory Use – Part 1: General Requirements
IEC 60079-0:2017 EN ISO 60079-0:2018 CAN/CSA C22.2 No. 60079-0:19 ANSI/UL 60079-0-2020 Seventh Edition	Explosive atmospheres – Part 0: Equipment – General requirements
IEC 60079-11:2011 EN 60079-11:2012 CAN/CSA C22.2 No. 60079-11:14 (R2018) ANSI/UL 60079-11-2018 Sixth Edition	Explosive atmospheres – Part 11: Equipment protection by intrinsic safety “i”
IEC 60529 CSA C22.2 No 60529: 05	Degrees of Protection provided by enclosures (IP Code)

B.2 CLASS I ZONE 0 AEx ia (H₂) Ga (SECTION APPLIES TO ONLY MODELS 53XY CLASS I, ZONE 0 AND 5846 CLASS I, ZONE 0)

B.2.1 CONDITIONS OF USE

1. The equipment is Certified for process pressure from 80 kPa (0.8 bar) to 110 kPa (1.1 bar). Process temperature: -40°C to +70°C.
2. The mating connector at the input shall provide an ingress protection level equivalent to the equipment, minimum of IP 66 or Type 4X.
3. If the equipment is used in a manner not specified in this installation manual, the protection provided by the equipment may be impaired.
4. The safety of any system incorporating the equipment is the responsibility of the assembler of the system.
5. The external housing shall be grounded in the end application per the manual.
6. The equipment has not been assessed as a combustible gas detector and shall not be used as a safety device.
7. The equipment shall be protected from direct mechanical impact or friction in the end application. Refer to installation manual.

B.2.2 SAFETY INTERFACE PARAMETERS

Supply:

U_i = 15.6 V; I_i = 160 mA, P_i = 2 W; C_i = 10 nF; L_i = 36.11 μH [no cable]
 U_i = 15.6 V; I_i = 160 mA, P_i = 2 W; C_i = 22 nF; L_i = 169 μH [with 30m cable]*

RS485 Interface:

U_i = 6 V; I_i = 160 mA, P_i = 150 mW; C_i = 7.5 μF; L_i = 1 μH [no cable]
 U_i = 6 V; I_i = 160 mA, P_i = 150 mW; C_i = 7.8 μF; L_i = 133 μH [with 30m cable]*

U_o = 6.52 V; I_o = 330 mA, P_o = 537 mW; C_o = 3.5 μF; L_o = 163.25 μH [no cable]
 U_o = 6.52 V; I_o = 330 mA, P_o = 537 mW; C_o = 3.4 μF; L_o = 30.25 μH [with 30m cable]*

Analog Outputs:

U_i = 28 V; I_i = 100 mA, P_i = 750 mW; C_i = 69 nF; L_i = 1 μH [no cable]
 U_i = 28 V; I_i = 100 mA, P_i = 750 mW; C_i = 81 nF; L_i = 133 μH [with 30m cable]

Digital Outputs:

U_i = 10 V; I_i = 40 mA, P_i = 200 mW; C_i = 10 nF; L_i = 1 μH [no cable]
 U_i = 10 V; I_i = 40 mA, P_i = 200 mW; C_i = 34 nF; L_i = 133 μH [with 30m cable]*

***A 50% reduction in cable length may apply in end application.**

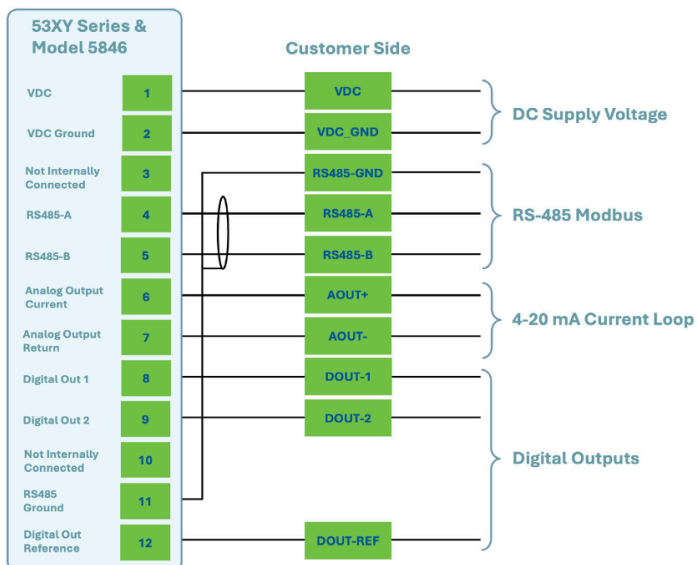

Figure 2: Typical Wiring Diagram

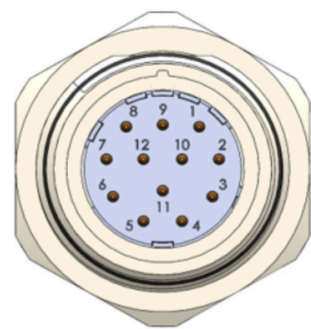

Figure 3: Connector Pin-Out

B.2.3 RECOMMENDED BARRIERS

When operated in a hazardous area, the Analyzer must be connected to appropriately certified barriers located in a non-hazardous area using H2scan specified cables. The following barriers are recommended to use with this device for an Intrinsically Safe implementation (refer to individual manufacturer's data sheets for proper connection and operation):

- **Intrinsically Safe Power Barrier:** R. STAHL, INC. Ex I Power Supply, P/N 9143/10-156-160-10s
- **Intrinsically Safe Serial Interface Barrier (RS485):** R. STAHL, INC. Fieldbus Isolating Repeater, P/N 9185/11-35-10s
- **Intrinsically Safe Analog Output Barrier (4 mA to 20 mA):** R. STAHL, INC. Transmitter Supply Unit, Ex i Field Circuit, P/N 9160/13-11-11s
- **Intrinsically Safe Digital Output Barrier:** R. STAHL, INC. Switching Repeater, Ex i Field Circuit, P/N 9170/21-11-11s

⚠ CAUTION

This equipment shall only be powered by a limited energy electric circuit in accordance with CAN/CSA C22.2 No. 61010-1-12 and ANSI/UL 61010-1, or Class 2 as defined in the Canadian Electrical Code C22.1, Section 16-200 and/or National Electrical Code (NFPA 70), article 725.121, when installed in non-hazardous locations.

B.2.4 CABLES

Only use cables specified by H2scan with this Analyzer. The maximum length of cable for intrinsically safe operation is 30 m. Cable connector is designed to be hand tighten to provide a seal.

B.3 CLASS I DIV 2 (H₂) (SECTION APPLIES TO ONLY MODELS 5846 CLASS I, DIV 2)

B.3.1 CONDITIONS OF USE

1. The equipment is Certified for process pressure from 80 kPa (0.8 bar) to 110 kPa (1.1 bar). Process temperature: -40°C to +70°C.
2. The mating connector at the input shall provide an ingress protection level equivalent to the equipment, minimum of IP 66 or Type 4X.
3. The equipment shall be wired per an acceptable method for Division 2 per the Canadian Electrical Code C22.1, Section 18 and/or National Electrical Code (NFPA 70), Article 501.
4. The external housing shall be grounded in the end application per the manual. If used in ordinary locations, this equipment shall only be powered by a limited energy electric circuit in accordance with CAN/CSA C22.2 No. 61010-1-12 and ANSI/UL 61010-1, or Class 2 as defined in the Canadian Electrical Code C22.1, Section 16-200 and/or National Electrical Code (NFPA 70), article 725.121.
5. If the equipment is used in a manner not specified in this installation manual, the protection provided by the equipment may be impaired.
6. The safety of any system incorporating the equipment is the responsibility of the assembler of the system.
7. The equipment has not been assessed as a combustible gas detector and shall not be used as a safety device.

B.4 PRODUCT MARKINGS

B.4.1 53XY CLASS I ZONE 0 AEx ia (H₂) Ga

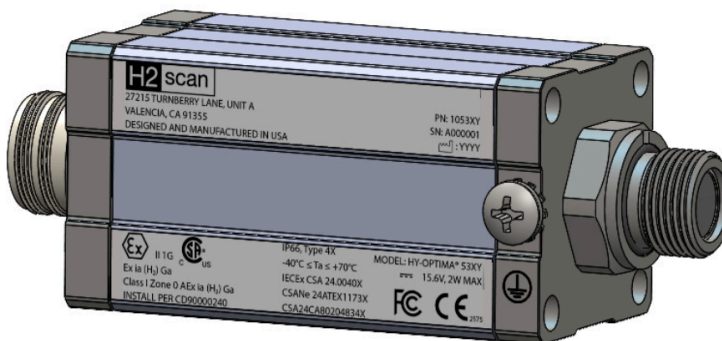

Figure 4: Product Marking



Figure 5: 53XY Product Marking - Upper

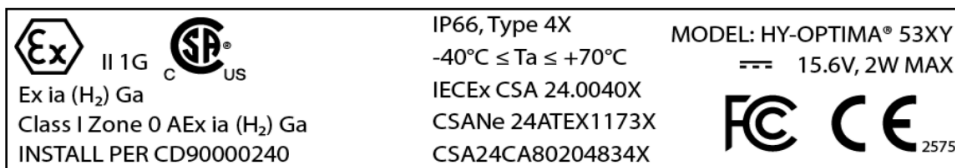

Figure 6: 53XY Zone 0 Product Marking - Lower

B.4.2 5846 CLASS I ZONE 0 AEx ia (H₂) Ga



Figure 7: Model 5846 Product Marking - Upper

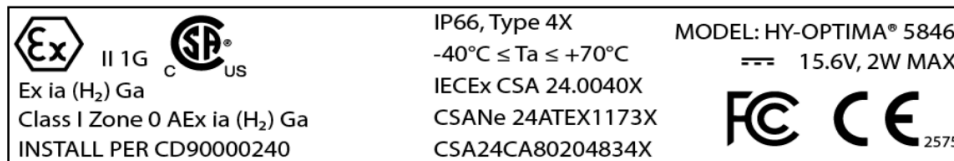

Figure 8: Model 5846 Zone 0 Product Marking - Lower

B.4.3 5846 CLASS I DIV 2 (H₂)



Figure 9: Model 5846 Product Marking - Upper

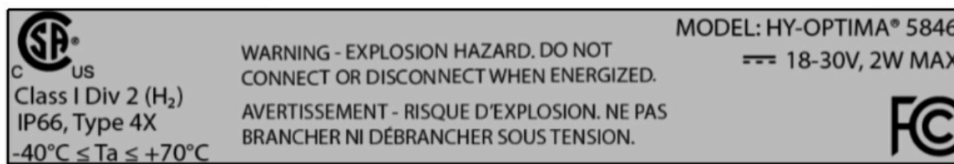

Figure 10: Model 5846 Class I Div 2 Product Marking - Lower

REVISION HISTORY

REVISION	DATE	Description
1	03/27/25	<ul style="list-style-type: none"> • Formatting changes to implement 5846 Class I Div 2 • Added "Class I Div 2" relevant information in B.1.1 • Change to "-40°C" in B.2.1 and B.3.1 • Removed "Minimum of IP 66 or Type 4X" and added ground exemption in B.1.3 • Revised Figure 2, updated destination of individual wiring • Revised Figure 4, changed marking to "-40°C" • Revised Figure 6, changed marking to "-40°C" • Added Figure 7 for 5846 CLASS I ZONE 0 AEx ia (H2) Ga • Added Figure 8 for 5846 CLASS I ZONE 0 AEx ia (H2) Ga • Added Figure 9 for 5846 CLASS I DIV 2 (H2) • Added Figure 10 for 5846 CLASS I DIV 2 (H2)
2	04/02/25	<ul style="list-style-type: none"> • Revised Figure 10 for 5846 CLASS I DIV 2 (H2), added "WARNING - EXPLOSION HAZARD. DO NOT CONNECT OR DISCONNECT WHEN ENERGIZED" and "AVERTISSEMENT - RISQUE D'EXPLOSION. NE PAS BRANCHER NI DÉBRANCHER SOUS TENSION."
3	04/04/25	<ul style="list-style-type: none"> • Added 2 rows to the Revision History table. • Replaced H2scan logo on header of every page with revised logo that has the registration symbol

APPENDIX C: OTHER STANDARDS

Beyond the scope of CSA certification, this equipment is in compliance with the following standards:

- IEC 60068-2-2 & EN 50155 Section 13.4.4
- IEC 60068-2-11 & DIN EN ISO 12944
- IEC 60068-2-6 table C.2
- IEC 60068-2-64 paragraph A.2, category no. 2
- IEC 60068-2-27
- FCC Part 15
- IC, RSS-Gen and RSS-210
- AS/NZS 4268

APPENDIX D: TROUBLESHOOTING

1. Verify the analyzer is reporting H₂.
 - Check all connections and flow paths.
 - Reduce process or calibration gas stream pressure to 1.0 ATA and power cycle the analyzer.
2. Verify the pressure and flow are stable.

NOTE: Unstable pressure or flow can cause the analyzer to behave erratically. Ensure the process gas stream is properly regulated. The analyzer is less sensitive to changes in flow, but a flow rate of 1.0 SLPM is recommended.

3. Check the stability of the analyzer output.
 - Expose the analyzer to a calibration gas (40–100% H₂, but not exceeding 10% H₂ in the model 5331 or 5% H₂ in the model 5332) overnight while recording the H₂ reading.
 - Plot the H₂ reading (you may use spreadsheet software, such as Microsoft Excel). Assuming a constant pressure, temperature, and flow rate, the H₂ line for the most recent data should be flat with no perturbations outside the defined specifications for the analyzer. If it is not yet stable, leave the analyzer exposed to the calibration gas for another 24 hours or until stability is observed.
 - Once the analyzer is stable, perform a two-point field calibration per [4.2](#).
 - If the analyzer does not stabilize, contact H2scan for support.
4. Evaluate whether the analyzer has been exposed to substances that may have damaged it.

NOTE: Exposure to liquids, acids, bases, or levels of H₂S or CO that exceed the product limits will damage the analyzer.

NOTE: Exposure to H₂ partial pressures that exceed the product limits will damage the analyzer.